



A world's leading manufacturer of power tools

 Double Insulation

 Bevel Cutting

190 mm (7-1/2") Circular Saw

Model 5705R (with carbide-tipped saw blade)

Sturdy, well designed construction for the maximum comfortable cuttings.



NEW



A world's leading manufacturer of power tools

Equipped with advanced power



Performance Data

Note: It may differ under some conditions.

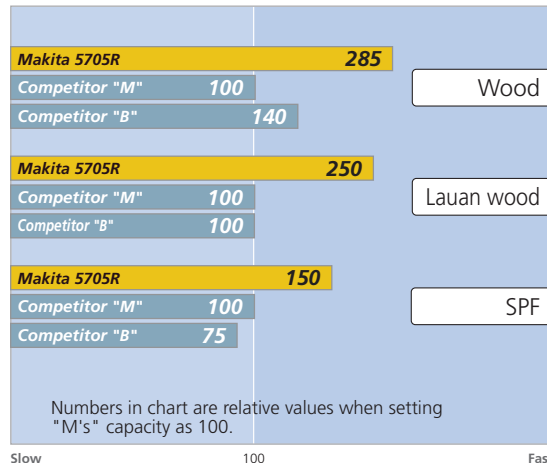

Powerful Rated Input

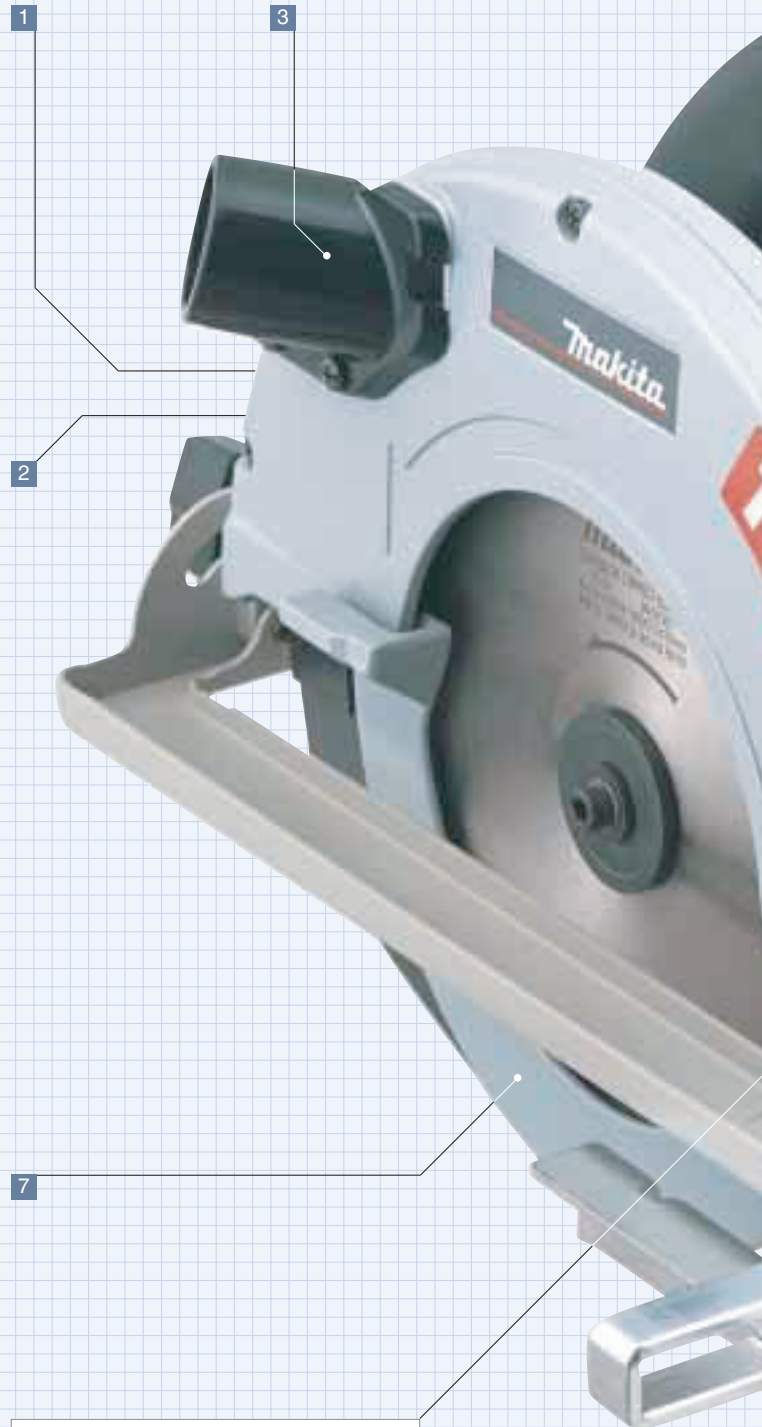

12 teeth Carbide-tipped saw blade for fast and clean cutting.

ful 1400W motor for more heavy-duty works.

Power: 1,400W



1. Depth adjusting lever



Easy-to-operate lever for adjusting cut depth.

2. Depth guide



Sturdy aluminum depth guide assures accurate bevel cutting.

3. Connection to vacuum cleaner



Large ejection port for smooth saw dust outflow; ready to accept joint set for dust collection.

4. Large, comfortable front grip

Can be hold tightly with large front grip that will help steady cutting.

5. Flat Top Design of Motor Housing

This flat top design of motor housing is very convenient for changing the blade.

6. Shaft lock

Shaft lock for easy blade replacement.

7. Aluminum safety coverguard

Aluminum safety cover (lower guard) moves smoothly. It has rollers on its end for smooth, scratch-free action over surface of material.

Specifications

Circular Saw



Double Insulation



45° Bevel Cutting

Blade diameter	190 mm (7-1/2")
Max. cutting capacities	at 90° 66 mm (2-5/8") at 45° 46 mm (1-13/16")
Continuous rating	
Input	1,400 W
No load speed	4,800 min ⁻¹ (rpm)
Overall length	356 mm (14")
Net weight	5.2 kg (11.5 lbs)
Power supply cord	2.5 m (8.2 ft.)
Specifications may differ from country to country.	

Dimension

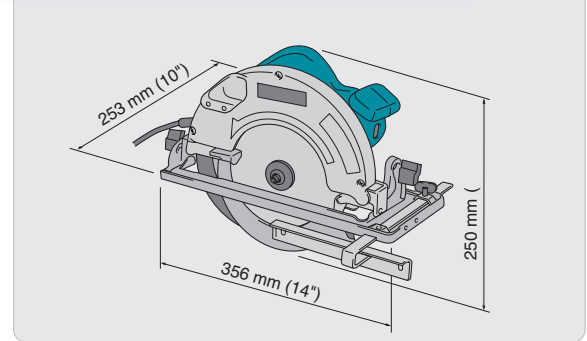

Standard equipment

Circular Saw

	Part No.
T.C.T Saw Blade 190mm (7-1/2") [Arbor : ø30 mm (1-3/16"), Number of teeth : 12]	B-02939
Guide Rule	165108-8
Joint set (for connecting to Makita vacuum cleaners)	192420-3
Hex. Wrench 5	783203-8

Optional accessories / Applications

Circular Saw

	Part No.
T.C.T Saw Blade 190mm (7-1/2") [Arbor : ø30 mm (1-3/16"), Number of teeth : 12]	B-02939
Inner flange 40 (for blades of arbor diameter 20mm [3/4"])	165108-8
Joint set (for connecting to Makita vacuum cleaners)	192420-3
Guide rail and Guide rail adapter (for accurate cutting of long workpieces)	783203-8



Model 406 Hose Standard equipment inner dia. 36mm



Model 431 Hose Standard equipment inner dia. 28mm

Circular Saw
5705R



2 Joint
(Dust nozzle)

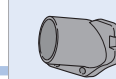

P/N 415517-4

