





A world's leading manufacturer of power tools

 Double Insulation

 Electronic speed control

 Dust Collecting

9 mm (3/8") Belt Sander

Model 9032

Makita new power-file sander enables you to file and sand in awkward and confined areas, replacing manual works.





A world's leading manufacturer of power tools

Various sanding arms and sanding belts, 10 mm (3/8") and 13 mm (1/2"), assures a wide range of applications.

9 mm (3/8") Belt Sander Model 9032

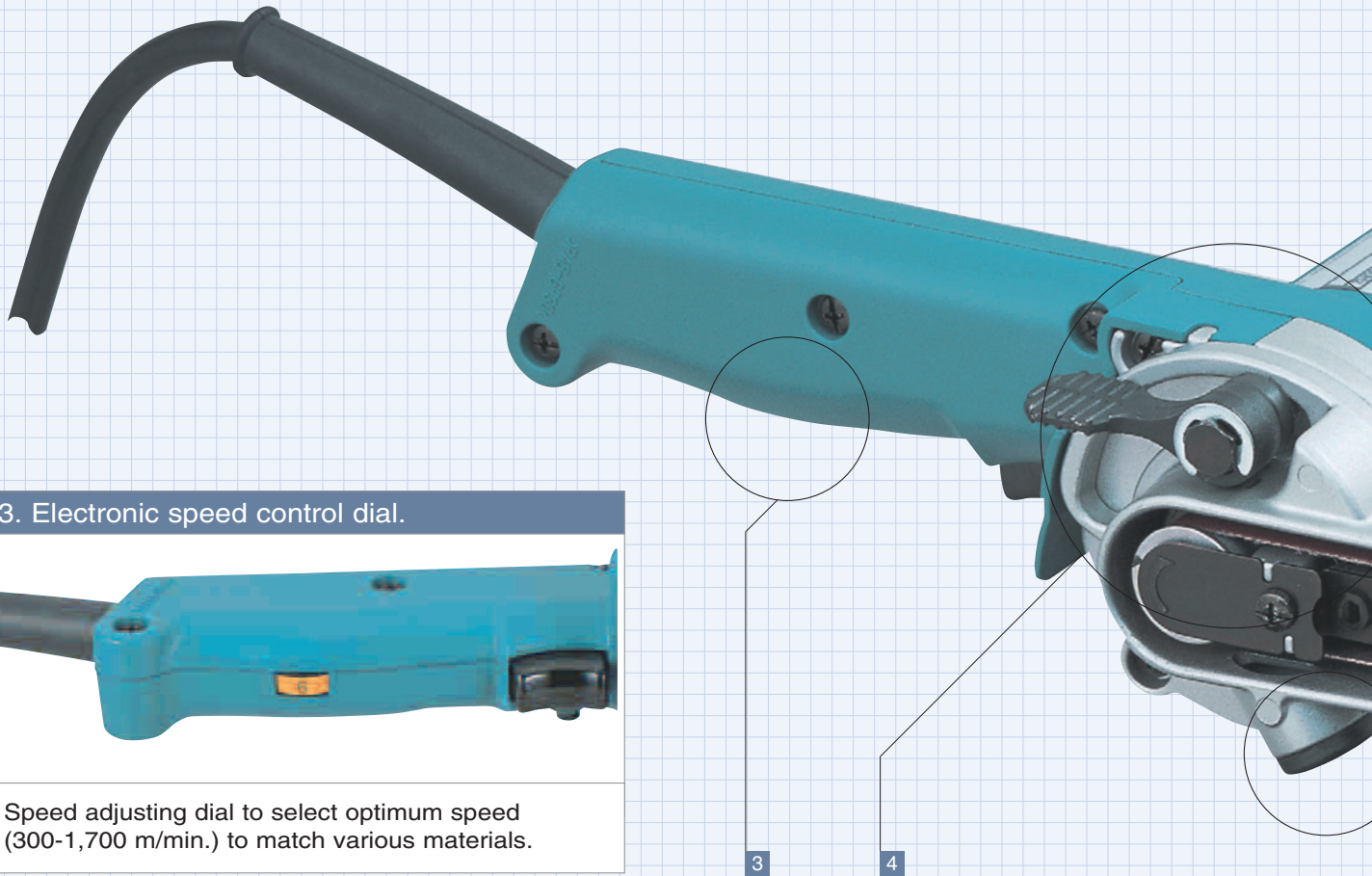

3. Electronic speed control dial.



Speed adjusting dial to select optimum speed (300-1,700 m/min.) to match various materials.

4. Adjustable sanding arm.

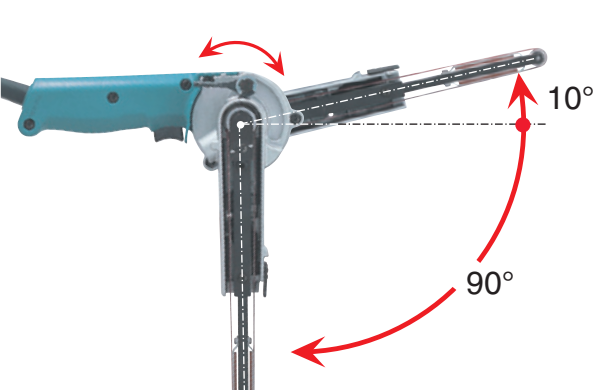

All sanding arms can be swiveled at the above angle for your convenience.

5. Dust-free work with dust extraction system.

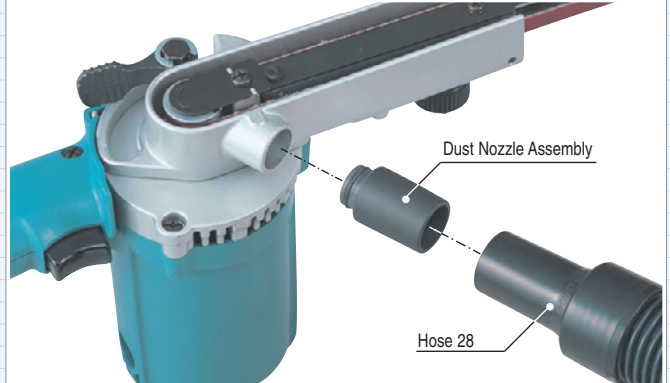

Dust extraction directly at the power-file sander (See the above feature) assures a dust free and efficient work. Use Dust Nozzle Assembly and Hose 28 (28 mm diameter hose).

Sanding belt widths, 6 mm (1/4"), 9 mm (3/8") wider range of sanding and filing applications.

1. Precise adjustment for the belt position can be done by turning the knob on the sander.

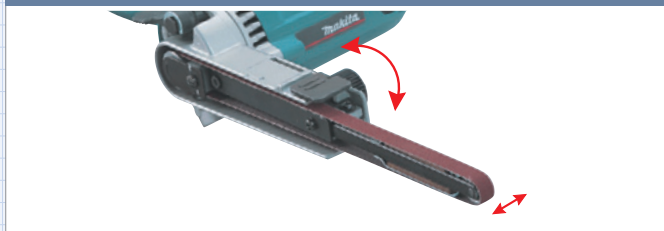

2. A belt can be easily replaced by simply pulling the lever (See the figure below).

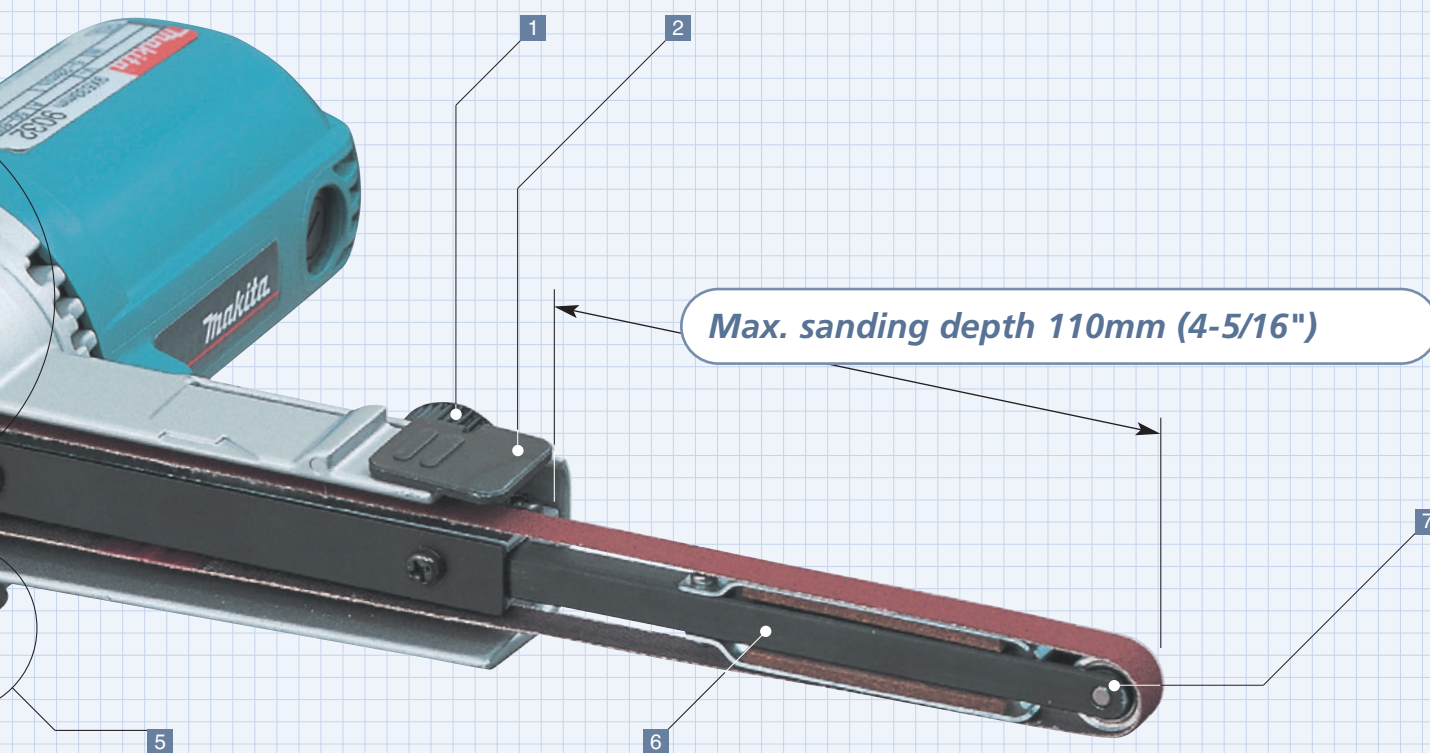
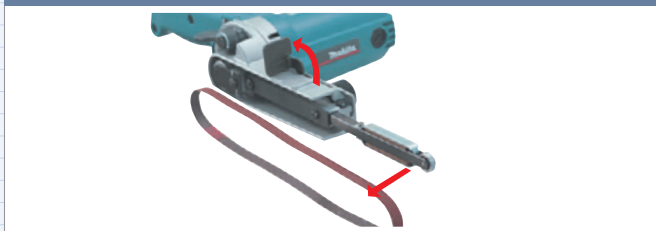

6. 3 different sized sand arms and belts are available for your various works.

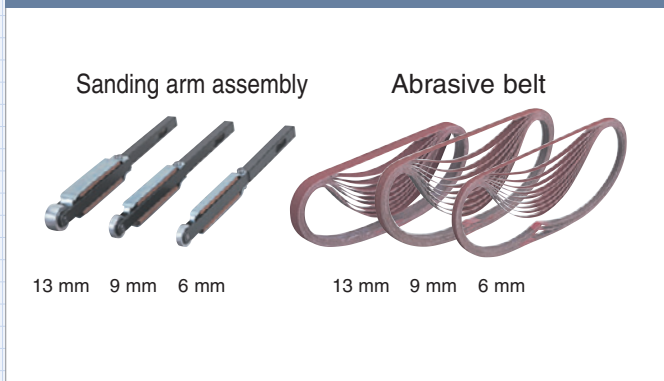

6 mm and 13 mm sized sand arms and belts as optional accessories.

7. Convenient slim tension roller with a diameter of only 14 mm enables you to do sanding and filing in confined spots.

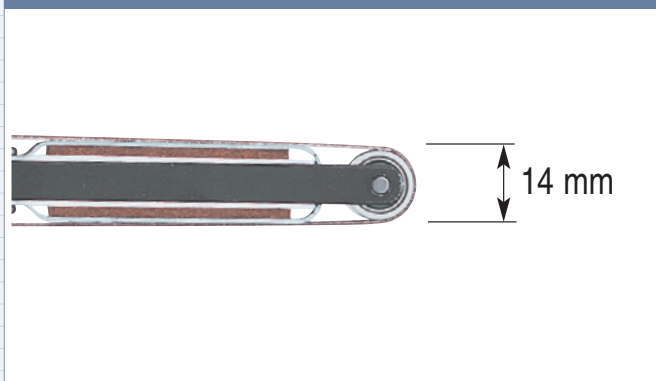

Specifications

Belt Sander

 Double Insulation

 Electronic speed control

 Dust Collecting

Dimension

Belt size	9 mm x 533 mm (3/8" x 21")
Belt speed	300 – 1,700 m / min. (980 – 5,600 ft./ min.)
Max. sanding depth	110 mm (4-5/16")
Continuous rating	
Input	500 W
Overall length	420 mm (16-1/2")
Net weight	1.5 kg (3.3 lbs)
Power supply cord	2.5 m (8.2 ft.)
Specifications may differ from country to country.	

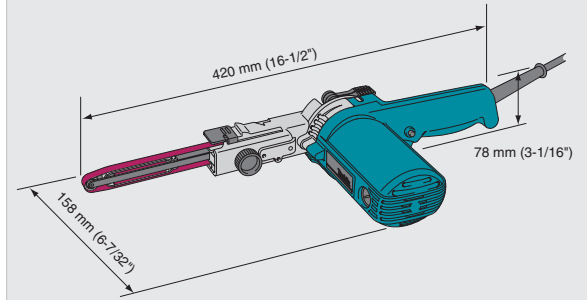

Standard equipment

Belt Sander

	Part No.
Sanding belt 9 - 533 grit 80 2 pcs.	A-34469*
Dust nozzle assembly (only for European countries)	122652-8

* 10 pcs/set part No.

Items of standard equipment may differ from country to country.

Optional accessories

Belt Sander

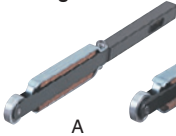
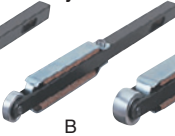
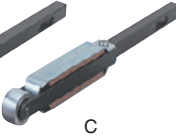
Sanding arm Assembly		
		
A	B	C
	Size	Part No.
	A 6 mm	125157-7
	B 9 mm	125158-5
	C 13 mm	125159-3

Dust Nozzle Assembly	
	
	Part No. 122652-8

Hose 28	
	
	Size 1.5 m
	Part No. 192278-0
	Size 3 m
	Part No. 192279-8

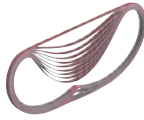
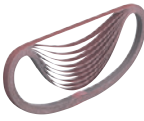
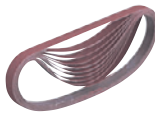
Abrasive Belt (10pcs/set)			
	6 x 533 mm	Grit 40	Part No. A-34512
		60	A-34528
		80	A-34534
		100	A-34540
	9 x 533 mm	120	A-34556
		40	A-34447
		60	A-34453
		80	A-34469
	13 x 533 mm	100	A-34475
		120	A-34481
		40	A-34562
		60	A-34578
	80	A-34584	
	100	A-34590	
	120	A-34609	