



A world's leading manufacturer of power tools

Double Insulation

Hook & Loop (BO4900V, BO4900)

Dust Collecting

Variable Speed (BO4900V)

Finishing Sander

Model BO4900V, BO4900, BO4901

*Newest Finishing Sanders from Makita
Minimized Vibration, Ergonomic Handles
and Efficient Dust Collection System for More
Comfortable and More Controlled Operations.*



PHOTO: Model BO4900V



Model BO4900V



Model BO4900



Model BO4901

NEW



A world's leading manufacturer of power tools

Ergonomic design and powerful 330W



PHOTO: Model BO4900V

Finishing Sander

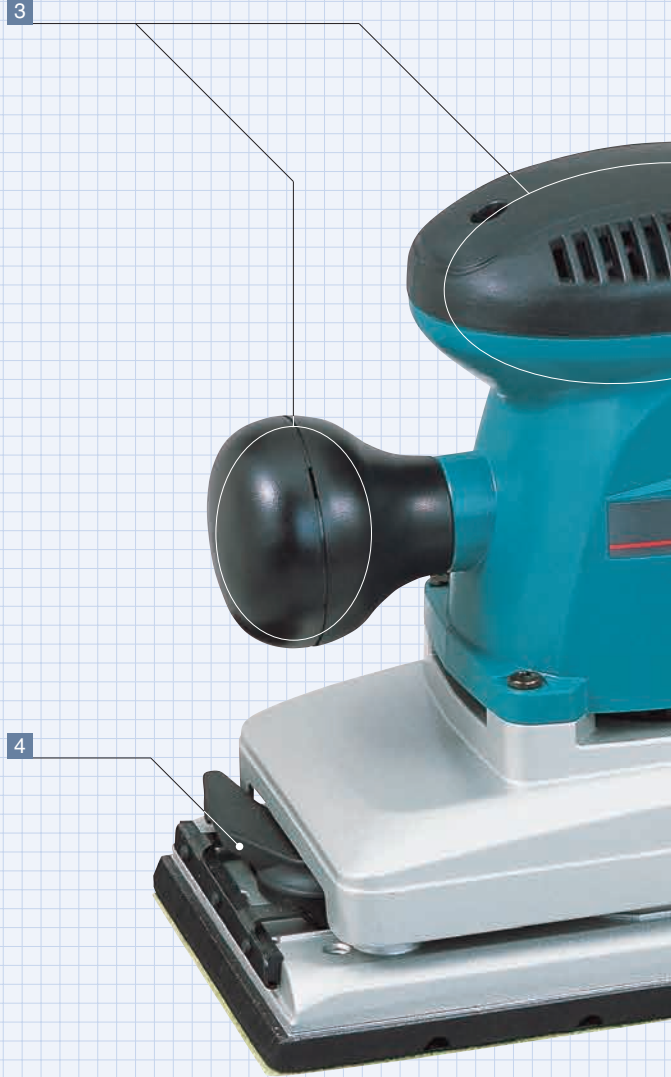

Performance Data

Note: It may differ under some conditions.

Volume of sanding

■ Work piece : spruce
With abrasive paper #120

Makita BO4900V / BO4900 / BO4901 110

Competitor "F" 100

Competitor "B" 90

90 100 110

Numbers in chart are relative values when setting competitor "F's" capacity as 100.

3. Ergonomic Grip & Housing top



The knob-style front handle and the low housing top of round design fit your palms perfectly for easy and comfortable handling.

4. Large Clamp



For quick and easy

motor for superior handling and ultra smooth finishes.

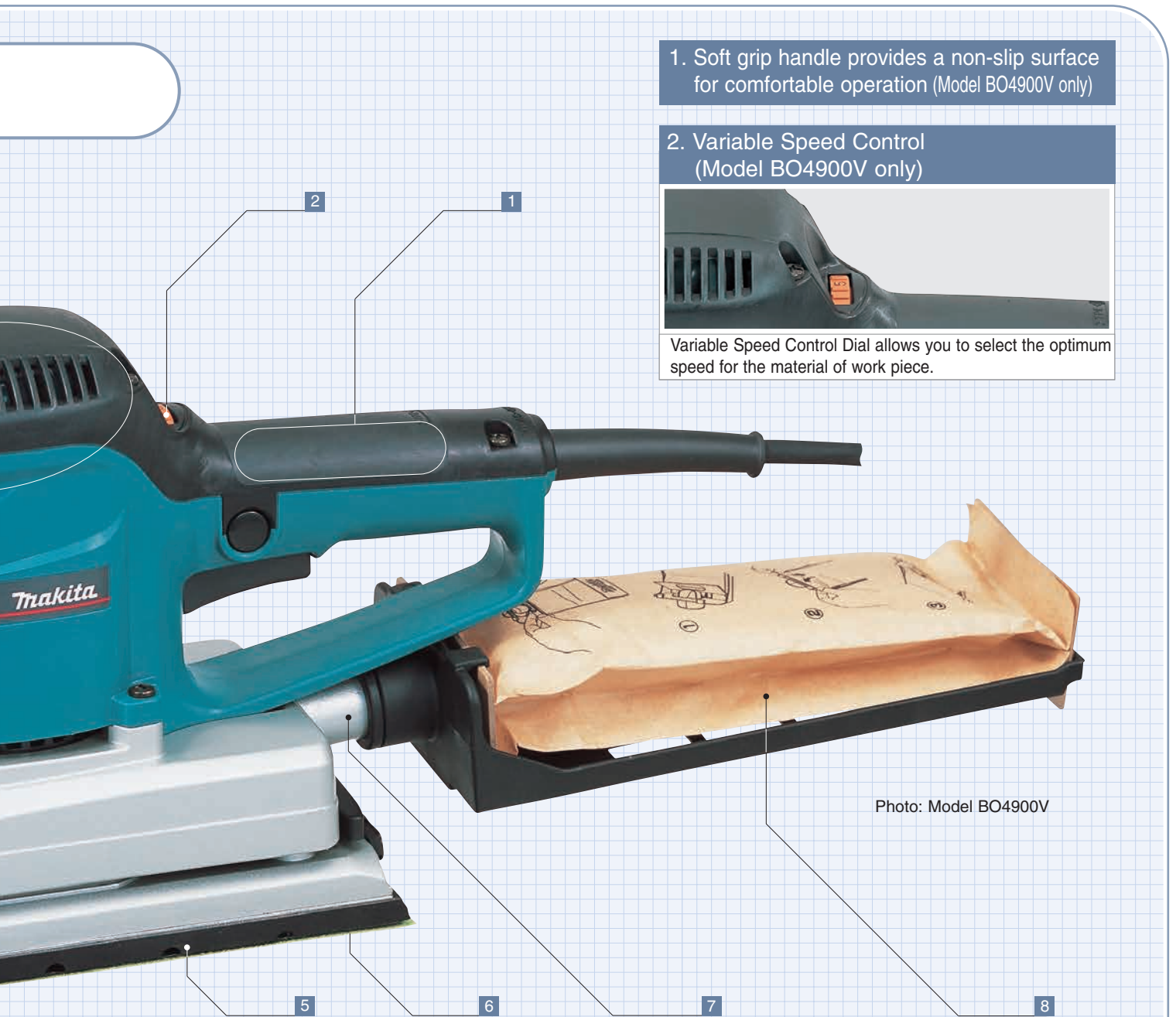

1. Soft grip handle provides a non-slip surface for comfortable operation (Model BO4900V only)

2. Variable Speed Control (Model BO4900V only)



Variable Speed Control Dial allows you to select the optimum speed for the material of work piece.

Photo: Model BO4900V

Changing Lever



Changing of abrasive paper.

5. Hook-and-Loop abrasive paper



FESTO and BOSCH abrasive papers can be used for BO4900V and BO4900. Papers for Makita 9046 are also applicable for these two models.

6. Through-the-Pad Dust Collection System

Extra-efficient dust collection for dust-free operation: Powerful suction through 10 pre-punched holes of abrasive paper and pad into dust bag or vacuum cleaner.

7. Easy connecting with vacuum cleaner

Can be connected to \varnothing 28 mm hose without any attachment.

8. Paper dust bag (Model BO4900V, BO4900)

For easy disposal of collected dust.

Specifications

Finishing Sander

 Double Insulation

 Variable Speed (BO4900V)

 Dust Collecting

 Hook & Loop (BO4900V, BO4900)

Pad size	115 mm x 229 mm (4-1/2" x 9")
Abrasive paper size	
Clamp	115 mm x 280 mm (4-1/2" x 11")
Hook & loop*	115 mm x 232 mm (4-1/2" x 9-1/8")
Continuous rating	
Input	330 W
Orbits per minute (min ⁻¹)	4,000 – 10,000 (BO4900V) 10,000 (BO4900, BO4901)
Sanding stroke rate (min ⁻¹)	8,000 – 20,000 (BO4900V) 20,000 (BO4900, BO4901)
Orbit dia.	2.6 mm
Overall length	289 mm (11-3/8")
Net weight	2.8 kg (2.6 lbs)
Power supply cord	2.5 m (8.2 ft.)

* Model BO4901 use with pad set (optional accessory)

Specifications may differ from country to country.

Dimensions

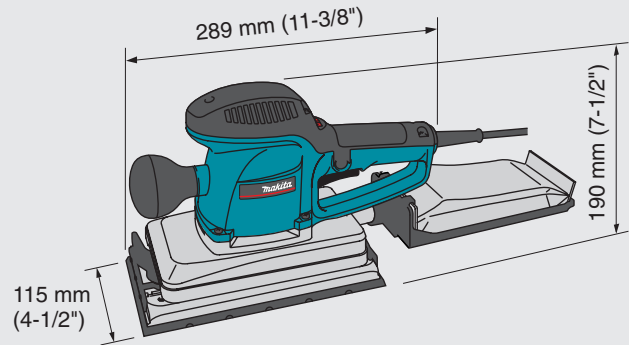

Standard equipment





Finishing Sander

	North America	Other Countries
	Part No.	Part No.
Pad set (For model BO4901)	193522-8	193521-0
Pad set (hook & loop) (For model BO4900V, BO4900)	193524-4	193523-6
Paper dust bag holder (For model BO4900V, BO4900) Paper dust bag holder comes with a paper dust bag.	193525-2	193294-5
Abrasive paper #120 (pre-punched) 1pc.	A-14093 (10pcs per pkg.)	

Items of standard equipment may differ from country to country.

Optional accessories

Finishing Sander

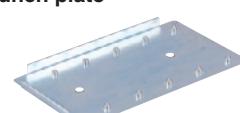
Abrasive paper (10per pkg.) 	Grit	Part No.	Dust bag complete 	Part No. 151517-7						
	60	794210-6								
	80	794470-0								
	100	794209-1								
	120	794212-2								
	150	794213-0								
Abrasive paper (10per pkg. Pre-punched) 	180	794211-1	Paper dust bag (5per pkg.) 	<table border="1"> <thead> <tr> <th>Part No.</th> <th>Part No.</th> </tr> </thead> <tbody> <tr> <td>North America</td> <td>193293-7</td> </tr> <tr> <td>Other Countries</td> <td>193526-0</td> </tr> </tbody> </table>	Part No.	Part No.	North America	193293-7	Other Countries	193526-0
	Part No.	Part No.								
	North America	193293-7								
	Other Countries	193526-0								
	60	A-14065								
	80	A-14071								
100	A-14087									
120	A-14093									
150	A-14102									
Abrasive paper (5per pkg. Pre-punched, hook & loop) 	180	A-14118	Punch plate 	Part No. 192523-3						
	240	A-14124								
	60	A-14130								
	80	A-14146								
	100	A-14152								
	120	A-14168								
150	A-14174	Part No. 151518-5								
180	A-14180									
240	A-14196									
			Dust nozzle complete	151518-5						
			Joint 25	192349-3						
			Joint (for Festo)	417408-5						

Makita Corporation

3-11-8, Sumiyoshi-cho, Anjo, Aichi 446-8502, Japan

PRINTED IN JAPAN Z14316-2 2002-2