

Before returning this product call

1-800-4-DEWALT

IF YOU SHOULD EXPERIENCE A PROBLEM WITH YOUR DEWALT PURCHASE,

CALL 1-800-4 DEWALT

IN MOST CASES, A DEWALT REPRESENTATIVE CAN RESOLVE YOUR PROBLEM OVER THE PHONE.

IF YOU HAVE A SUGGESTION OR COMMENT, GIVE US A CALL. YOUR FEEDBACK IS VITAL TO THE SUCCESS OF DEWALT'S QUALITY IMPROVEMENT PROGRAM.

Questions? See us on the World Wide Web at www.dewalt.com

INSTRUCTION MANUAL
GUIDE D'UTILISATION
MANUAL DE INSTRUCCIONES

INSTRUCTIVO DE OPERACIÓN, CENTROS DE SERVICIO
Y PÓLIZA DE GARANTÍA. **ADVERTENCIA:** LÉASE ESTE
INSTRUCTIVO ANTES DE USAR EL PRODUCTO.

**See the Quick Start Guide
on page 4!**

*Se reporter en page 17
du Guide de démarrage !*

*¡Vea la Guía de referencia rápida
en la página 31!*

DEWALT®

D24000 Wet Tile Saw

Coupe-tuile à l'eau D24000

Sierra de corte húmedo D24000

IF YOU HAVE ANY QUESTIONS OR COMMENTS ABOUT THIS OR ANY DEWALT TOOL, CALL US TOLL FREE AT: 1-800-4-DEWALT (1-800-433-9258)

This product is covered under U.S. Patent No. D486,165 and other patents pending.

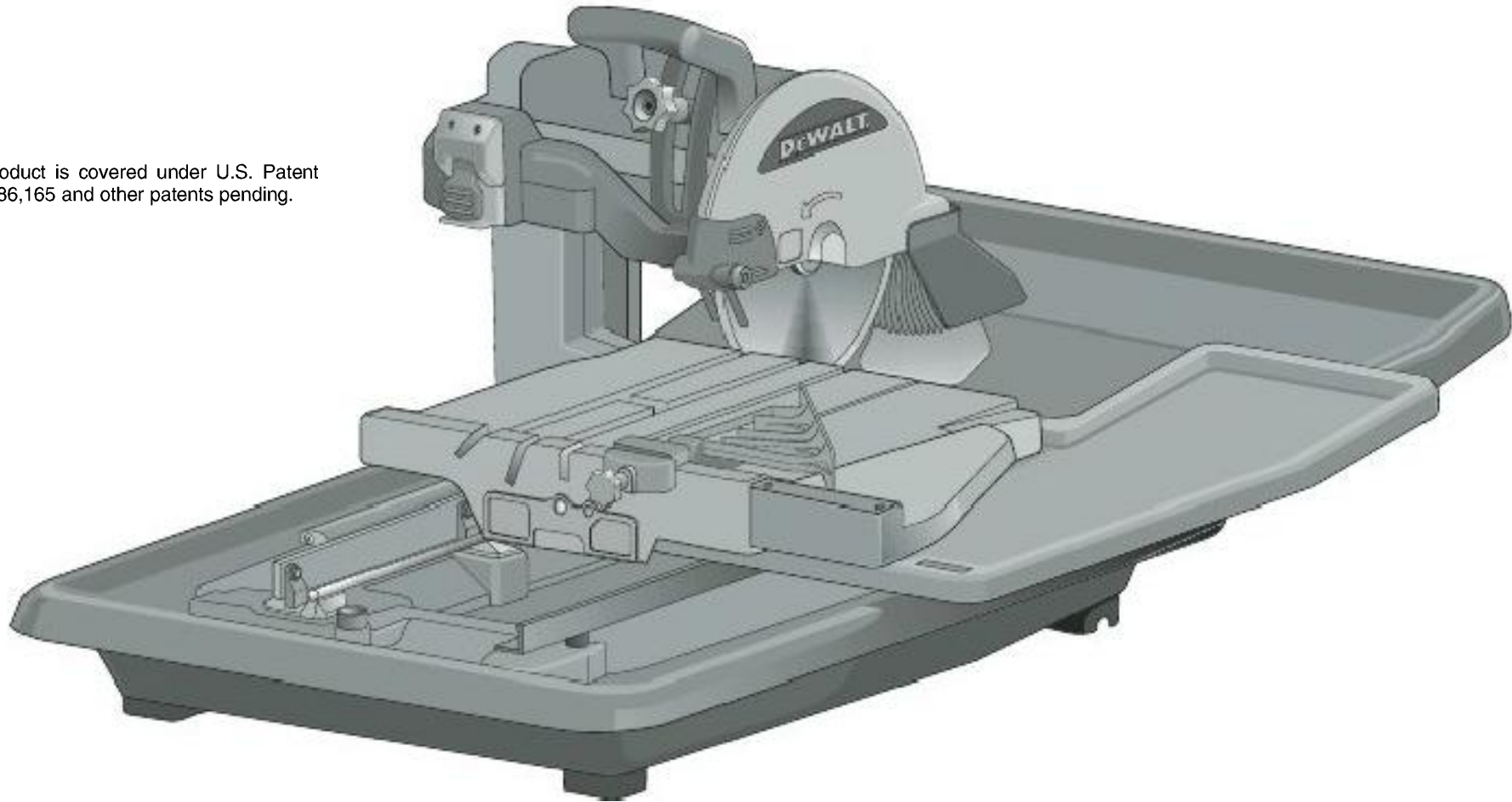

DEWALT... BUILT JOBSITE TOUGH

DEWALT high performance industrial tools are made for America's toughest industrial and construction applications. The design of every tool in the line – from drills to sanders to grinders – is the result of rigorous use on jobsites and throughout the industry. Each tool is produced with painstaking precision using advanced manufacturing systems and intense quality control. Every tool is checked before it leaves the factory to make sure that it meets your standards for durability, reliability and power.

DEWALT Built Jobsite Tough **WE GUARANTEE IT.**

TABLE OF CONTENTS

IMPORTANT SAFETY INSTRUCTIONS FOR ALL TOOLS	2	CLEANING.....	10
GROUNDING INSTRUCTIONS	2	LUBRICATION.....	10
ADDITIONAL SAFETY RULES FOR WET TILE SAWS	3	REPAIRS	10
QUICK START GUIDE	4	ACCESSORIES.....	10
FEATURES	6	WARRANTY	10
ASSEMBLY	6	TROUBLESHOOTING GUIDE	11
SPECIFICATIONS	7		
OPERATION	7		
TOOL PLACEMENT	7		
MOTOR	7		
ON/OFF SWITCH	7		
WATER NOZZLES.....	7		
CUTTING WHEEL ALIGNMENT	7		
CUTTING WHEEL DEPTH	7		
MAKING A CUT	7		
LOCKING THE CUTTING CART	8		
TYPES OF CUT.....	8		
ADJUSTMENTS.....	9		
MAINTENANCE.....	10		
BRUSHES	10		
TRANSPORTATION AND STORAGE.....	10		

Important Safety Instructions for All Tools

WARNING: For your own safety, read the instruction manual before operating the wet tile saw. Failure to heed these warnings may result in personal injury and serious damage to the saw. When servicing this tool, use only identical replacement parts. Have damaged cords replaced by an authorized service center.

GROUNDING INSTRUCTIONS

- In the event of a malfunction or breakdown, grounding provides a path of least resistance for electric current to reduce the risk of electric shock. This tool is equipped with an electric cord having an equipment-grounding conductor and a grounding plug. The plug must be plugged into a matching outlet that is properly installed and grounded in accordance with all local codes and ordinances.
- Do not modify the plug provided – if it will not fit the outlet, have the proper outlet installed by a qualified electrician.
- Improper connection of the equipment-grounding conductor can result in a risk of electric shock. The conductor with insulation having an outer surface that is green with or without yellow stripes is the equipment-grounding conductor. If repair or replacement of the electric cord or plug is necessary, do not connect the equipment-grounding conductor to a live terminal.
- Check with a qualified electrician or service personnel if the grounding instructions are not completely understood, or if in doubt as to whether the tool is properly grounded.
- Use only 3-wire extension cords that have 3-prong grounding plugs and 3-pole receptacles that accept the tool's plug.
- Repair or replace damaged or worn cord immediately.

This tool should be grounded while in use to protect the operator from electric shock. The tool is equipped with a 3-conductor cord and 3-prong grounding type plug to fit the proper grounding type receptacle. The green (or green and yellow) conductor in the cord is the grounding wire. Never connect the green (or green and yellow) wire to a live terminal. If your unit is intended for use on less than 150 V, it has a plug that looks like that shown in sketch a. If it is for use on 150 to 250 V, it has a plug that looks like that shown in sketch d. An adapter, sketches b and c, is available for connecting sketch A type plugs to 2-prong receptacles. The green-colored rigid ear, lug, or the like, extending from the adapter must be connected to a permanent ground, such as a properly grounded outlet box. No adapter is available for a plug as shown in sketch d. ADAPTER SHOWN IN SKETCHES B and C IS NOT FOR USE IN CANADA.

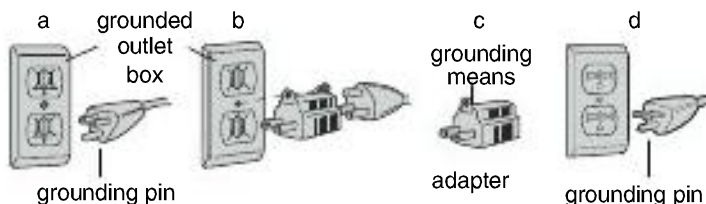

WARNING: To reduce the risk of electrocution, keep all connections dry and off the ground.

WARNING: A Ground Fault Circuit Interrupter (GFCI) is provided for use with the saw. Receptacles are available having built in GFCI protection and may be used for an added measure of safety. When using an extension cord, the GFCI should be installed to the power supply before the extension cord.

WARNING: The water pump must be plugged into a GFCI protected receptacle.

NOTE: Do not run the pump dry.

WARNING: Test GFCI before each use:

- Plug GFCI into power outlet. Indicator should turn red.
- Press test button. Red indicator should disappear.

3. Press reset button for use. Do not use if above test fails.

CAUTION: WHEN SERVICING USE ONLY IDENTICAL REPLACEMENT PARTS. Repair or replace damaged cords. Always replace cord with a GFCI cord.

WARNING: Never use saw with salt water or a conductive fluid.

WARNING: When using electric tools, basic safety precautions should always be followed to reduce risk of fire, electric shock, and personal injury, including the following:

- KEEP GUARDS IN PLACE** and in working order.
- REMOVE ADJUSTING KEYS AND WRENCHES.** Form habit of checking to see that keys and adjusting wrenches are removed from tool before turning it on.
- KEEP WORK AREA CLEAN.** Cluttered areas and benches invite injuries.
- DON'T USE IN DANGEROUS ENVIRONMENT.** Don't use power tools in damp or wet locations, or expose them to rain or snow. Keep work area well lighted.
- KEEP CHILDREN AWAY.** All visitors should be kept safe distance from work area.
- MAKE WORKSHOP KID PROOF** with padlocks, master switches, or by removing starter keys.
- DON'T FORCE TOOL.** It will do the job better and safer at the rate for which it was designed.
- USE RIGHT TOOL.** Don't force tool or attachment to do a job for which it was not designed.
- USE PROPER EXTENSION CORD.** Make sure your extension cord is in good condition. When using an extension cord, be sure to use one heavy enough to carry the current your product will draw. An undersized cord will cause a drop in line voltage resulting in loss of power and overheating. The following table shows the correct size to use depending on cord length and nameplate ampere rating. If in doubt, use the next heavier gage. The smaller the gage number, the heavier the cord.

Minimum Gage for Cord Sets

Volts	Total Length of Cord in Feet			
	0-25	26-50	51-100	101-150
120V				
Ampere Rating		AWG		
More Than	Not more Than			
12	- 16	14	12	Not Recommended

- WEAR PROPER APPAREL.** Do not wear loose clothing, gloves, neckties, rings, bracelets, or other jewelry which may get caught in moving parts. Nonslip footwear is recommended. Wear protective hair covering to contain long hair. Air vents often cover moving parts and should also be avoided.
- ALWAYS USE SAFETY GLASSES.** Also use face or dust mask if cutting operation is dusty. Everyday eyeglasses only have impact resistant lenses, they are NOT safety glasses.
- SECURE WORK.** Always place tile flat on cart and securely against fence.
- NEVER USE A PAN HEATER OR OTHER HEAT SOURCE FOR HEATING WATER.** Damage to the tool, fire or personal injury could result.
- DON'T OVERREACH.** Keep proper footing and balance at all times.
- MAINTAIN TOOLS WITH CARE.** Keep tools sharp and clean for best and safest performance. Follow instructions for lubricating and changing accessories.
- DISCONNECT TOOLS** before servicing; when changing accessories, such as cutting wheels, clamps, extensions, and the like.
- REDUCE THE RISK OF UNINTENTIONAL STARTING.** Make sure switch is in off position before plugging in.
- USE RECOMMENDED ACCESSORIES.** Consult the instruction manual for recommended accessories. The use of improper accessories may cause risk of injury to persons.
- NEVER STAND ON TOOL.** Serious injury could occur if the tool is tipped or if the cutting tool is unintentionally contacted.

- **CHECK DAMAGED PARTS.** Before further use of the tool, a guard or other part that is damaged should be carefully checked to determine that it will operate properly and perform its intended function—check for alignment of moving parts, binding of moving parts, breakage of parts, mounting, and any other conditions that may affect its operation. A guard or other part that is damaged should be properly repaired or replaced.
- **DIRECTION OF FEED.** Feed work into a cutting wheel with the direction of rotation only.
- **NEVER LEAVE TOOL RUNNING UNATTENDED. TURN POWER OFF.** Don't leave tool until it comes to a complete stop.
- **REPLACEMENT PARTS.** When servicing, use only identical replacement parts.

Additional Safety Rules for Wet Tile Saw

⚠ **WARNING:** To reduce the risk of electrocution, keep all connections dry and off the ground. Do not touch plug with wet hands.

⚠ **CAUTION:** Wear appropriate hearing protection during use. Under some conditions and duration of use, noise from this product may contribute to hearing loss.

⚠ **CAUTION:** Do not connect unit to electrical power source until complete instructions are read and understood.

- Use safety equipment. Always wear eye protection. Dust mask, non-skid safety shoes, hard hat, or hearing protection must be used for appropriate conditions.
- Keep hands out of path of saw cutting wheel. **NEVER CUT A PIECE WHERE HAND WOULD BE 3" (76mm) OR LESS FROM CUTTING WHEEL.**
- Do not operate saw without cover in place.
- Do not perform any operation freehand, that is without holding the workpiece firmly against the fence and guide.
- Never reach in back of the cutting wheel.
- DO - Use cutting cart extension to support large tile.
- DON'T - Cut dry. If cutting wheel is not cooled with water, serious damage will occur. Dry cutting will increase exposure to harmful airborne dust.
- Turn off the tool and wait for cutting wheel to stop before moving the workpiece or changing settings.
- To reduce risk of injury, return the carriage to the full rear position after each cut.
- DO - Protect electric supply line with at least a 15 ampere time-delay fuse or a circuit breaker.
- DO - Make certain the cutting wheel rotates in the correct direction as indicated by the arrow on the cutting wheel.
- DO - Be sure all clamp handles and knobs are tight before starting any operation.
- DO - Be sure all cutting wheel and clamp washers are clean and recessed sides of collars are against cutting wheel. Tighten arbor screw securely.
- DO - Keep the cutting wheel properly aligned.
- DO - Keep the motor air slots free of chips and dirt.
- DO - Keep hands out of the path of the saw cutting wheel.
- DO - Shut off power, disconnect cord from power source and wait for the saw cutting wheel to stop before servicing, adjusting tool or changing cutting wheel.
- DON'T - Attempt to operate on anything but designated voltage. Incorrect voltage may result in shock, fire, or unpredictable operation.
- DON'T - Operate unless all knobs and clamp handles are tight.
- DON'T - Use cutting wheels larger or smaller than those which are recommended.
- DON'T - **Force cutting action. Allow motor to reach full speed before cutting.** Stalling or partial stalling of motor can cause major damage.
- DON'T - Use metal cutting abrasive wheels. The excessive heat and abrasive particles generated by them will damage the saw.
- DO - Use continuous rim wheels only, no serrated edges.
- DON'T - Allow anyone to stand behind saw.
- DON'T - Place either hand in the cutting wheel area when the saw is connected to the power source.

- DON'T - Use cutting wheels rated less than 5000 R.P.M.
- DON'T - Place hands closer than 3" (76 mm) from the saw cutting wheel.
- DON'T - Reach behind or underneath the saw unless it is turned off and unplugged.
- DON'T - Move either hand from saw or workpiece until the cutting wheel has stopped.
- If the plug or receptacle does get wet. DON'T unplug the cord. Disconnect the fuse or circuit breaker that supplies power to the tool. Then unplug and examine for presence of water in the receptacle.

⚠ **WARNING:** Some dust created by power sanding, sawing, grinding, drilling, and other construction activities contains chemicals known to cause cancer, birth defects or other reproductive harm. Some examples of these chemicals are:

- lead from lead-based paints,
- crystalline silica from bricks, cement, tile, natural stone and other masonry products,
- arsenic and chromium from chemically-treated lumber (CCA).

Your risk from these exposures varies, depending on how often you do this type of work. To reduce your exposure to these chemicals: work in a well ventilated area, and work with approved safety equipment, such as those dust masks that are specially designed to filter out microscopic particles.

• **Avoid prolonged contact with dust from power sanding, sawing, grinding, drilling, and other construction activities. Wear protective clothing and wash exposed areas with soap and water.** Allowing dust to get into your mouth, eyes, or lay on the skin may promote absorption of harmful chemicals.

⚠ **WARNING:** Use of this tool can generate and/or disburse dust, which may cause serious and permanent respiratory or other injury. Always use NIOSH/OSHA approved respiratory protection appropriate for the dust exposure. Direct particles away from face and body.

For your convenience and safety, the following warning labels are on your Wet Tile Cutter.

ON COLUMN

⚠ **WARNING: FOR YOUR OWN SAFETY, READ INSTRUCTION MANUAL BEFORE OPERATING TILE SAW.**

ALWAYS USE EYE PROTECTION.

ALWAYS USE PROPER RESPIRATORY PROTECTION.

KEEP HANDS OUT OF PATH OF CUTTING WHEEL.

USE TOOL ONLY WITH SMOOTH EDGE CUTTING WHEELS FREE OF OPENINGS AND GROOVES.

DO NOT OPERATE SAW WITHOUT COVERS IN PLACE.

ALWAYS TIGHTEN ADJUSTMENT KNOBS BEFORE USE.

DO NOT PERFORM ANY OPERATION FREEHAND.

NEVER REACH IN BACK OF CUTTING WHEEL.

NEVER CROSS ARMS IN FRONT OF CUTTING WHEEL.

TURN OFF TOOL AND WAIT FOR CUTTING WHEEL TO STOP BEFORE MOVING WORK PIECE OR CHANGING SETTINGS.

DISCONNECT POWER BEFORE CHANGING CUTTING WHEELS, SERVICING OR CLEANING.

TO REDUCE RISK OF INJURY ALWAYS PLUG TOOL INTO A GFCI RECEPTACLE AND TEST GFCI BEFORE USE.

ALWAYS RETURN CUTTING WHEEL TO PROPER POSITION BEFORE TURNING ON SAW.

USE SPLASH GUARD FOR EVERY OPERATION FOR WHICH IT CAN BE USED.

REPLACE DAMAGED CUTTING WHEEL BEFORE OPERATING.

DO NOT EXPOSE TO RAIN OR USE IN DAMP LOCATIONS.

NEVER USE PAN HEATER OR OTHER HEATER SOURCE FOR HEATING WATER. DAMAGE TO THE TOOL, FIRE OR PERSONAL INJURY COULD RESULT.

THINK! YOU CAN PREVENT ACCIDENTS.

ON CUTTING WHEEL COVER

CAUTION: PROPERLY SECURE COVER WITH BOTH SCREWS BEFORE USE.

ON CART

WARNING: TO REDUCE THE RISK OF INJURY, ALWAYS VERIFY THE CUTTING WHEEL IS ADJUSTED TO THE CORRECT HEIGHT AND LOCATION IN THE CENTER OF THE CART GROOVE BEFORE OPERATING SAW.

DEWALT

Quick Start Guide D24000 Wet Tile Saw

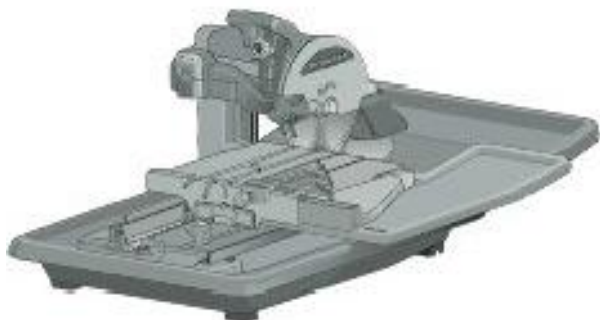

WARNING: For your own safety, read the instruction manual before operating the wet tile saw. Failure to heed these warnings may result in personal injury and serious damage to the saw. When servicing this tool, use only identical replacement parts. Have damaged cords replaced by an authorized service center.

FIG. 1

The motor arm assembly comes assembled. Open the box and lift the assembly out, as shown in Figure 1.



Step 1

1. Install the motor arm onto frame assembly. Using the wrench supplied, install and tighten the two screws closest to the rail first. Install and tighten the other two screws.

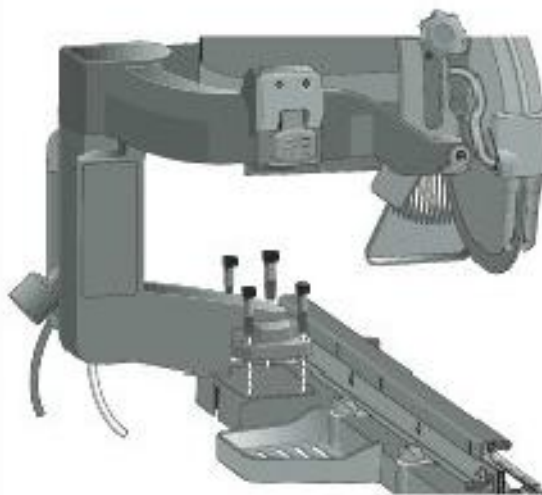

Step 2

2. Attach the cutting wheel.
 - a. Using the smaller Allen wrench supplied, loosen (do not remove) the screw on the side of the cutting wheel cover. Pull the rubber side flap back and lift the cover toward the rear of the saw.
 - b. Press spindle lock button. Remove the cutting wheel nut with hex wrench provided. Remove outer flange.
 - c. Install the cutting wheel with the rotational arrow facing the same way as on the rotational arrow on the cutting wheel cover. Press the spindle lock button while tightening the cutting wheel nut.
 - d. Replace cover and tighten screw.



For further details, refer to
To Attach Cutting Wheel
in the
Instruction Manual.

Step 3

3. Attach the cutting cart to the rails.

*For further details, refer to **Assembly** in the *Instruction Manual*.*

NOTE: Make sure the cart lock is in full open position.

- a. Align the arrow on the rear of the cutting cart with the round rail on the frame of the saw.

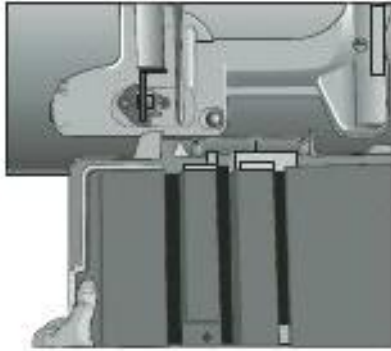

- b. Place the rear roller assembly onto the round rail.

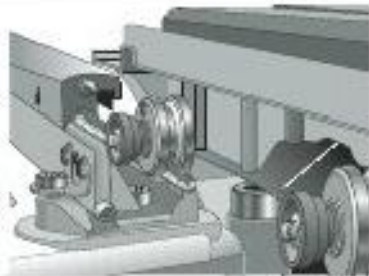

- c. Slide the cutting cart assembly onto the rail system. Tilt the front of the cart upward slightly to clear the cart stop.

**Step 4**

4. The outer rim of the cutting wheel should always be at least 3/16" (5mm) below the cart surface. Push cart entirely through the cutting wheel before cutting to be sure that the cutting wheel depth is properly adjusted to avoid cutting the cart. Adjust the depth of cut knob (BB) and tighten the locking wing nut (MM), then the head lock knob (D).

*For further details, refer to **Adjustments** in the *Instruction Manual*.*

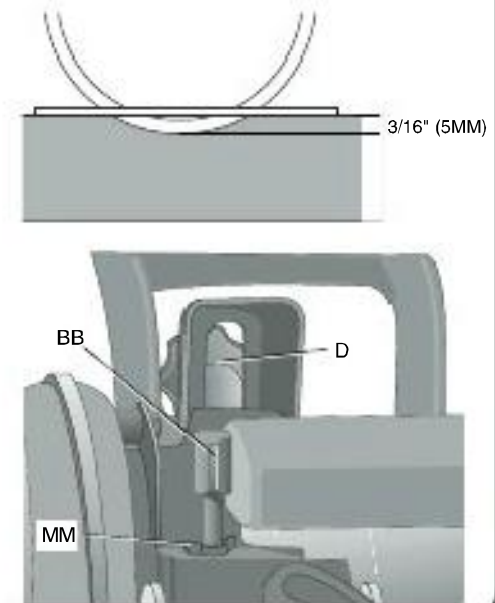
**Steps 5, 6, 7, 8**

5. Place the saw in the water pan. The water pan drain hole should be in the front position.
6. Attach the water pump to the water line and insert pump power cord into the socket. Position pump properly in pan, as shown.
7. Fill the pan with 5 gallons of water. The pump should be submerged.

NOTE: For longer pump life, always place the pump in a clean water source.

8. Turn saw on. If lower water flow is desired, use the flow restrictor on the water line.

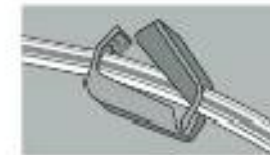
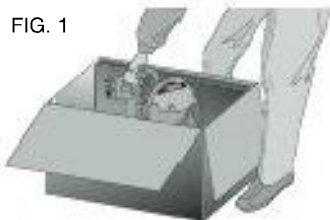

FIG. 1



FEATURES (Fig. 2-4)

The motor arm assembly comes assembled. Open the box and lift the assembly out, as shown in Figure 1.

- | | |
|--------------------------|----------------------------------|
| A. On/Off switch | I. Cutting cart water attachment |
| B. Motor arm assembly | J. Edge guide |
| C. Plunge handle | K. Water pan |
| D. Head lock knob | L. Saw frame assembly |
| E. Cutting wheel cover | M. Water nozzles |
| F. Cutting wheel | N. Water pump |
| G. Rear water attachment | PP. Cutting Cart Extension |
| H. Cutting cart assembly | |

ASSEMBLY (Fig. 2-4)

- Place saw frame assembly (L) on a stable surface.
- Using the supplied wrench remove the screws (O) from the saw frame assembly.
- Place motor arm (B) on frame assembly.
- Secure the saw head by installing two of the screws (O) into the holes closest to the rail. Tighten the screws with the wrench provided. Install the other two screws in the other two holes and tighten.
- Place the saw assembly into the water pan (K) as shown in Figure 2.
- Tilt the front of the cutting cart assembly (H) down on a slight angle. Align the arrow on the rear of the cutting cart with the round rail on the frame of the saw. Slide the cutting cart assembly onto the rail system clearing the cart stop with both pairs of rollers.
- Place the threaded fitting onto the water pump (N). Attach the clear water tube (P) to the threaded fitting (Fig. 4). Place the water pump in the deep corner of the water pan, near the drain plug. Insert the pump power cord into the socket (Q).
- Install rear water attachment (G).
- Install cutting cart water attachment (I).

TO ATTACH CUTTING WHEEL (FIG. 5)

- Using the smaller Allen wrench supplied, loosen (do not remove) the screw (R) on the side of the cutting wheel cover (E). Pull the rubber side flap back and lift the cover toward the rear of the saw.
- Press spindle lock button. Remove the cutting wheel nut (S) with hex wrench provided. Remove outer flange (T).
- Install the cutting wheel (F) with the rotational arrow facing the same way as on the rotational arrow on the

FIG. 2

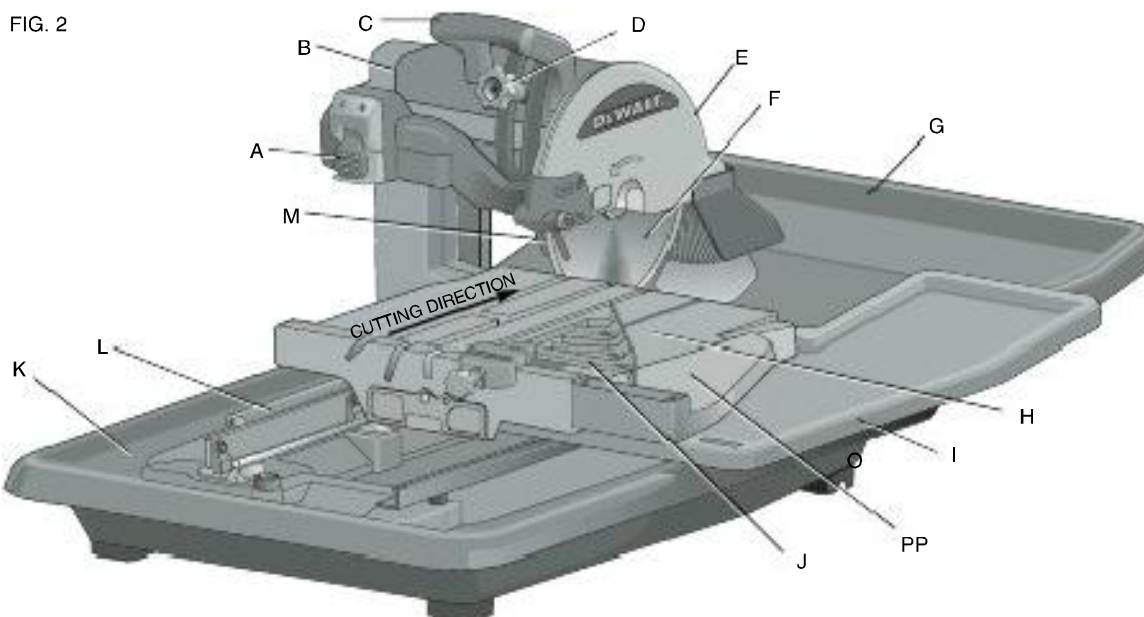

FIG. 3

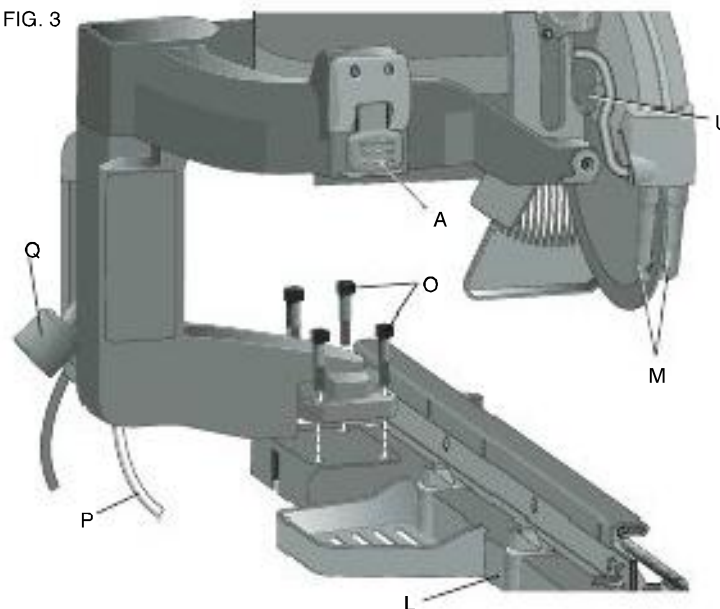
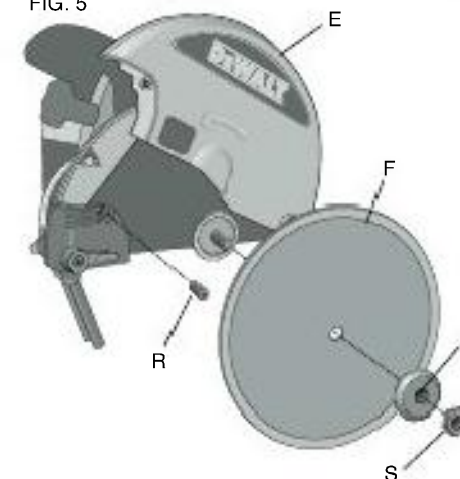

FIG. 4



FIG. 5



cutting wheel cover. Press the spindle lock button (U) while tightening the cutting wheel nut.

4. Replace cover and tighten screw (R).
5. Adjust cutting wheel depth (see **Cutting Depth Adjustment**).

TO ATTACH THE EDGE GUIDE (FIG. 12)

1. Place edge guide (J) on the cutting cart assembly (H).
2. Turn the edge guide lock (W) clockwise to tighten.

Specifications

Voltage.....	120 V
Amps	15A
RPM.....	4200
Depth of Cut	3-3/4"
Miter Angels.....	22.5° and 45°
Cutting Wheel sizes.....	7", 8", 9" and 10" Continuous Rim Cutting wheels and 6" Profile Wheel

OPERATION

Tool Placement

Place stand (D24001, see **Accessories**) on a level surface. Place the saw into the stand as shown in Figure 21. If not using a stand, place saw on a level surface.

Motor

Be sure your power supply agrees with the nameplate marking. Voltage decrease of more than 10% will cause loss of power and overheating. All DEWALT tools are factory tested; if this tool does not operate, check the power supply.

- Always plug saw into a GFCI receptacle.
- Always plug extension cord into a GFCI receptacle.
- Use only extension cords that are intended for outdoor use. These extension cords are identified by a marking "Acceptable for use with outdoor appliance; store indoors while not in use."
- Use only extension cords having an electrical rating not less than the rating of the product.
- Do not use damaged extension cords. Examine extension cord before using and replace if damaged.
- Do not abuse extension cords and do not yank on any cord to disconnect.
- Keep cord away from heat and sharp edges.
- Always disconnect the extension cord from the receptacle before disconnecting the product from the extension cord.

On/Off Switch

▲ WARNING: To avoid the possibility of the appliance plug or receptacle getting wet, position the wet tile saw to one side of a wall mounted receptacle to prevent water from dipping onto the receptacle or plug. The user should arrange a "drip loop" in the cord connecting the saw to a

FIG. 6

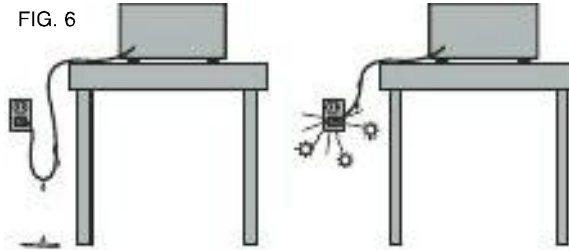

FIG. 7

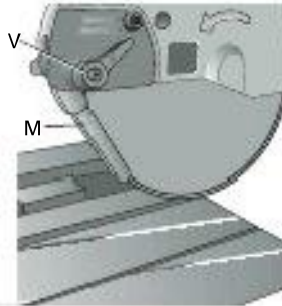

FIG. 8

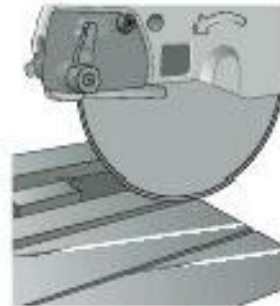

FIG. 9

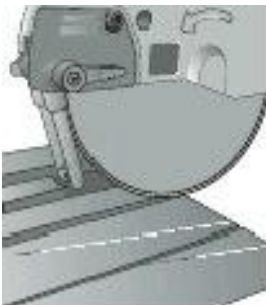

FIG. 10

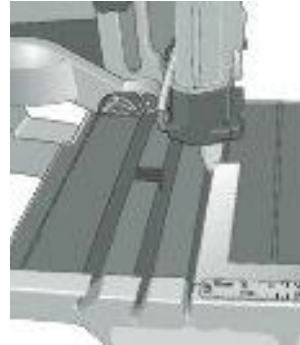
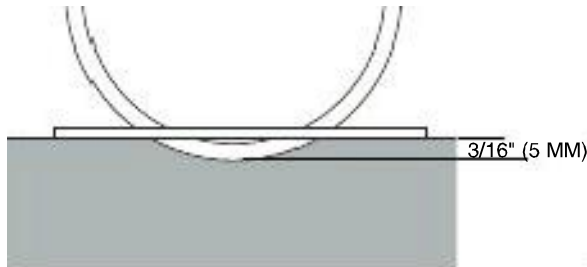

FIG. 11



receptacle (Fig. 6). The "drip loop" is that part of the cord below the level of the receptacle, or the connector if an extension cord is used, to prevent water traveling along the cord and coming in contact with the receptacle.

To turn the wet tile cutter on, lift up the on/off switch (A). The wet tile saw locks on automatically. To turn the tool off, push the on/off switch down. A hole is provided under the switch for insertion of a padlock to deter unauthorized use.

Water Nozzles

Water nozzles (M) are adjustable to provide maximum water for cutting and maximum capacity with the minimum amount of overspray and mist. The adjusting lever (V) allows easy adjustment of nozzles to desired position.

1. Optimum position for minimum overspray (Fig. 7).
2. Water nozzles (M) can be fully retracted to allow for maximum capacity (Fig. 8).
3. "Off Cutting Wheel" position to eliminate water overspray between cuts and for blade change (Fig. 9).

Cutting Wheel Alignment

TO CHECK ALIGNMENT (FIG. 10)

1. Place a 90° framing square on the cutting cart fence (X).
2. Push the cutting cart along the cutting wheel to determine if the gap along the framing square is consistent along the length of the stroke.
3. If the gap is not consistent, see the **Adjustments** section of this manual.

Cutting Wheel Depth (Fig. 11)

The outer rim of the cutting wheel should always be at least 3/16" (5mm) below the cart surface. Push cart entirely through the cutting wheel before cutting to be sure that the cutting wheel depth is properly adjusted to avoid cutting the cart.

If the cutting wheel height is not set, see the **Adjustments** section of this manual. Failure to adjust properly could cause damage or injury.

Making a Cut (Fig. 12)

▲ CAUTION: Turn off and unplug the tool before making any adjustments or removing or installing attachments or accessories. Be sure the switch is in the OFF position.

Before turning the saw on, verify the proper alignment of the cutting cart and cutting wheel. Always center the cutting wheel in one of the cutting cart grooves (Y) before cutting (0°, 22.5° or 45°). If the cutting wheel is not centered in the cart groove, please see the **Adjustments** section of this manual.

1. Fill a 5 gallon bucket with water. Submerge the water pump into the bucket.
2. Place the tile to be cut onto the cutting cart and secure the edge guide (J) with the edge guide lock (W). Always keep hands away from the cutting wheel.

- Pull up the on/off switch (A) to turn the saw on. Wait until the stream of water from the water pump completely covers the cutting wheel.

NOTE: Cutting tile without water will damage the cutting wheel.

- Ease the cutting cart toward the cutting wheel then slowly feed the tile into the cutting wheel. Continue pushing until the cutting wheel cuts completely through the tile.
- Turn the saw off by pushing the on/off switch (A) down.
- After the cutting wheel stops, remove the tile from the cutting cart.

Locking the Cutting Cart (Fig. 13)

There are three locking positions for the cart.

Move the cart to the desired position and lock the cart by rotating the pin (Z) and pushing it into a hole in the rail.

Types of Cuts (Figs. 12-15)

CAUTION: Turn off and unplug the tool before making any adjustments or removing or installing attachments or accessories. Be sure the trigger switch is in the OFF position.

Always do a dry or practice run to acquaint yourself with the path of the cutting wheel. Practice on a scrap tile to ensure that you are comfortable with the feel of the cutting operation. Push the cart past the cutting wheel before turning the saw on. Make sure the cutting wheel is adjusted to the center of the groove and to the proper height.

CUT INDICATOR

After setting the cutting wheel depth and doing a practice run, turn the saw on to cut a groove in the cut indicator (AA). See **Adjustments** for further information.

STRAIGHT CUTS

- Using a marker or grease pencil, mark the area to be cut on tile.
- Place the tile on the cutting cart against the cutting cart fence (X) and align your mark with the cutting wheel.
- Pull the on/off switch up to turn the saw on and wait for the cutting wheel to be completely covered with water.
- Ease the cutting cart toward the cutting wheel then slowly feed the tile into the cutting wheel. Continue pushing until the cutting wheel cuts completely through the tile.
- Turn off the saw.

DIAGONAL CUTS

Diagonal cuts are also referred to as "long point to long point cuts."

- Align the point of the tile closest to the cutting cart fence (X) with the cut indicator (AA). The cut indicator signifies the exact location where the cutting wheel will exit the cutting cart in the fence. Note that the cut indicator will need to be cut when first using the saw (see **Adjustments**).
- Align the front of the tile to the cutting wheel and hold against the edge guide.

FIG. 12

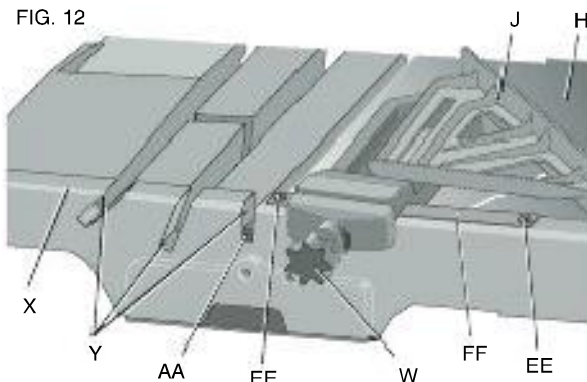

FIG. 13

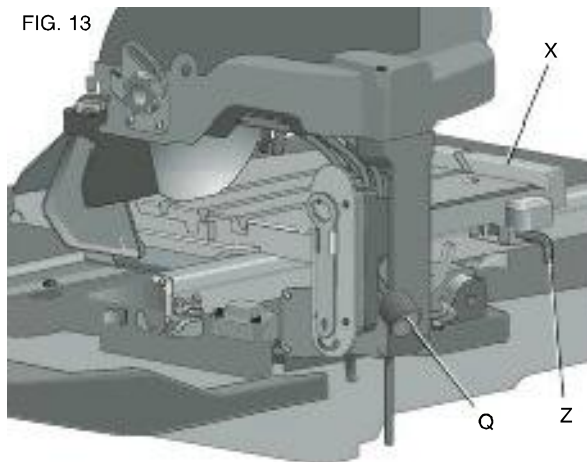

FIG. 14

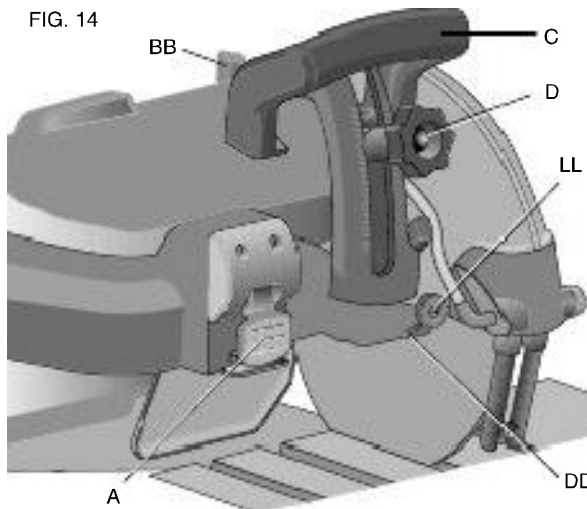
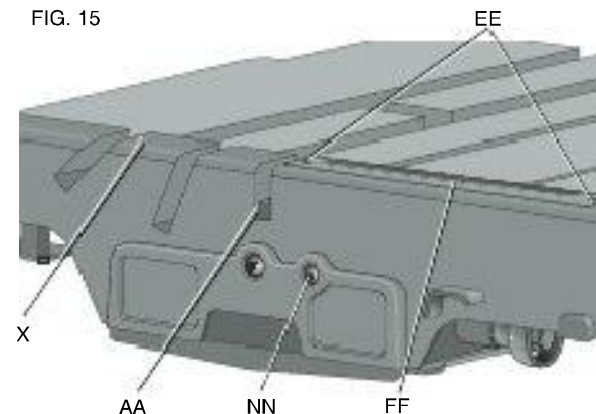

FIG. 15



- Turn the saw on and make the cut.
- Turn off the saw.

L-CUTS

An L-cut is a section that is removed from a piece of tile and is used when cutting a piece of tile to fit in a corner of a cabinet or piece of trim molding.

- Outline the area to be cut on both sides of the tile.
- Align the tile to the cutting cart fence and make the cut far enough into the tile without overcutting.
- Make a cut on the other mark on the tile without overcutting.
- Turn the tile over and make the cut along one of the outlines, but this time an overcut can occur without damaging the exposed surface of the tile due to the radius of the cutting wheel. Overcut the other line and the cut piece should be separate from the rest of the tile.
- Turn off the saw.

PLUNGE CUTS

Plunge cuts are utilized when removing the center of a piece of tile for electrical outlets and for making cuts for air conditioner registers.

- Outline the area to be cut on both sides of the tile.
- Release the cutting head by loosening the head lock knob (D).
- Adjust the depth of cut knob (BB) in the rear of the cutting wheel guard to prevent the cutting wheel from traveling too deep and cutting into the cutting cart. Always do a dry or practice run to acquaint yourself with the path of the cutting wheel. Practice on a scrap tile to ensure that you are comfortable with the feel of the cutting operation.
- Place the tile on the cutting cart with the finished side facing up.
- Align the mark with the cutting wheel.
- Turn the saw on. With one hand on the plunge handle (C) and one hand on the tile, keeping both hands at a

safe distance from the cutting wheel, lower the head of the saw slowly into the tile. Cut into the tile up to the edge of the mark without overcutting.

- Repeat the process on each outline without overcutting.
 - Turn the tile over. Repeat steps 2 and 3, overcutting along the lines which will allow the piece to fall out.
- NOTE:** The corners may need to be trimmed with tile nippers (not included with the saw).
- Turn off the saw.

MITER CUTS: 22.5° AND 45°

Miter cuts are used for cutting outside and inside corners on tile, decorative chair rail and base molding.

The cutting head of the saw is adjustable to three positions: 0°, 22.5° or 45°. The three grooves (Y) in the cutting cart allow for the cutting head to be set at the three settings without cutting into the cutting cart assembly (H).

- Loosen the bevel lock knob (CC) in the rear of the saw and adjust the head of the saw to the correct miter degree. The bevel pointer (DD) on the front of the saw will show the angle of adjustment.
- Always do a dry run and push the cart past the cutting wheel before turning on the saw. Ensure the cutting wheel is adjusted to the center of the groove.
- Mark the tile and line the tile against the fence of the cutting cart and the edge guide. Proceed to make the cut.
- Turn off the saw.

MOVING THE SAW

CAUTION: Do not attempt to move the saw while filled with water or personal injury may result.

Before moving the saw, be sure to drain the water pan by placing a 5 gallon bucket under the drain plug of the saw. Remove the drain plug and allow the water to empty into the bucket.

Adjustments (Fig. 15–17)

CAUTION: Turn off and unplug the tool before making any adjustments or removing or installing attachments or accessories. Be sure the switch is in the OFF position.

CUTTING CART SCALE

- Unplug the saw.
- Move the cart so the cutting wheel is near the cart fence. (X).
- Using a tape measure or scale, check the scale on the cart.
- If the scale is in error, loosen the two screws (EE) that hold the scale (FF) in place, adjust to the correct dimension and tighten the screws.

CUTTING WHEEL SQUARE TO CART

- Place a 90° square on the cutting cart.
- If the gap is not consistent, loosen the bevel lock knob (CC) and adjust the 0° bevel adjustment screw (GG)

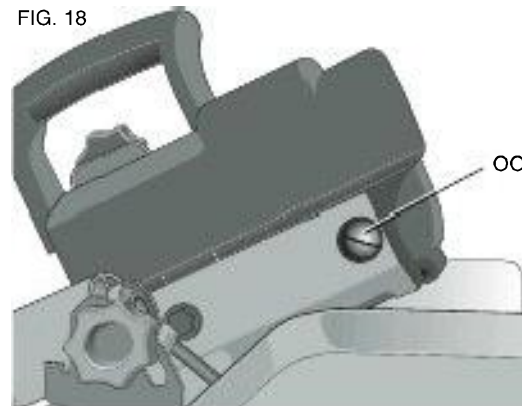
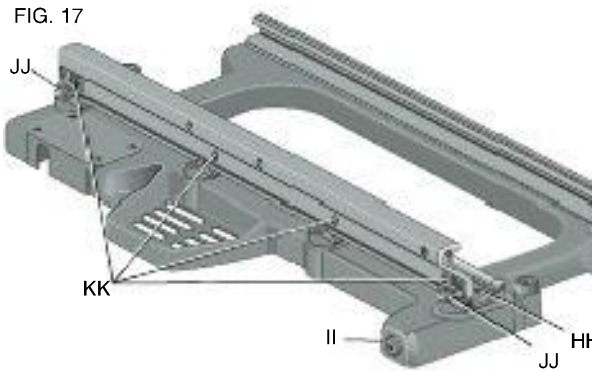
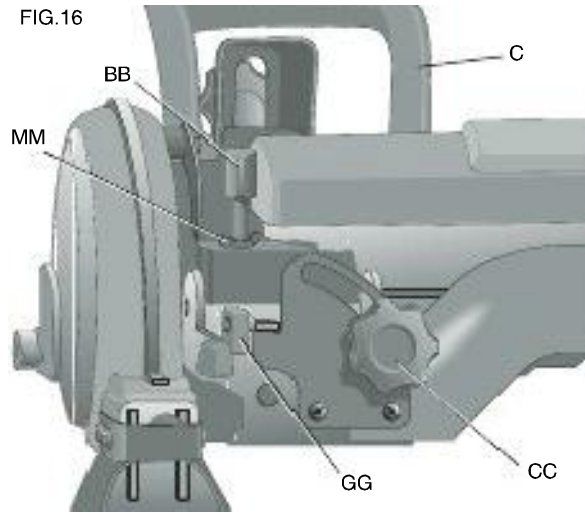

with supplied wrench until the cutting wheel is 90° to the cart surface.

- Ensure that the cutting wheel does not touch either side of the groove in the cutting cart by pushing the cart past the cutting wheel with saw turned off.

CUTTING WHEEL 45° TO THE CART

- Loosen bevel locking knob and rotate the cutting head to 45°.
- Put a 45° guide on the cutting cart surface next to the cutting wheel. If it is not at 45°, adjust the 45° bevel adjustment screw (GG) with the supplied wrench until the cutting wheel is 45° to the cart surface.
- With saw turned off, ensure that the cutting wheel does not touch either side of the groove in the cutting cart by pushing the cart past the cutting wheel.

CUTTING PARALLEL TO CUTTING CART

- Lay a 90° square flat on the cutting cart surface with one end against the cart fence (X).
- If the cutting wheel is not 90° to the cart fence, the rail will need adjustment.
- Loosen the four rail assembly mounting screws (HH).
- Position the rail adjuster (JJ) until the cutting wheel is square to the cart fence.
- Tighten the four rail screws.

CART ROLLING RESISTANCE (RAIL ADJUSTMENT)

- Loosen the four rail height screws (KK).
- Adjust the two rail height adjusters (JJ) until cart moves smoothly.
- Tighten the four screws.

BEVEL POINTER (FIG. 14)

Loosen the 0° bevel pointer screw (LL) and rotate the bevel pointer (DD) to the correct location.

DEPTH OF CUT

- Loosen head lock knob (D).
- Adjust depth of cut knob (BB) until the cutting wheel is at least 3/16" (5mm) below the cart surface.
- With the unit turned off, push the cart past the cutting wheel and ensure that the cutting wheel does not touch the cart.
- Adjust the depth of cut knob and tighten the locking wing nut (MM), then the head lock knob (D).

CUT INDICATOR

The cut indicator (AA) assists in aligning long and diagonal cuts by showing where the blade will exit the cut. The cut indicator can be used multiple times before adjustment is necessary.

- Loosen locking screw (NN).
- Rotate cut indicator to expose uncut surface.
- Tighten locking screw.

MAINTENANCE

Brushes (Fig. 18)

▲ CAUTION: Turn off and unplug the tool before making any adjustments or removing or installing attachments or accessories. Be sure the switch is in the OFF position.

Inspect carbon brushes regularly by unplugging tool, removing the brush cap (OO) and withdrawing the brush assembly. Keep brushes clean and sliding freely in their guides. Always insert a replacement brush in the same orientation in the holder as the used brush was prior to its removal. Carbon brushes have varying symbols stamped into their sides, and if the brush is worn down to the line closest to the spring, brushes must be replaced. Use only identical DEWALT brushes. Use of the correct grade of brush is essential for proper operation. New brush assemblies are available at DEWALT service centers. The tool should be allowed to "run in" (run at no load) for 10 minutes before use to seat new brushes.

Transportation and Storage

The rear water attachment (G), cutting cart water attachment (I) and water pan (K) may be nested together to make carrying easier (Fig. 19).

The edge guide (J) and the cutting cart extension (PP) may also be stored in the underside of the water pan (Fig. 20).

Cleaning

1. Insert the water pump into a bucket of clean water and pump the water through the hose system.
2. Turn off and unplug the saw from the power supply.
3. Place a 5 gallon bucket under the drain plug. Remove the drain plug and allow the water to empty into the bucket.
4. Slide the cutting cart off the rail system. Spray the cutting cart with a hose or wipe with a grout sponge or rag.
5. Wipe the rails, motor housing, and support arm with a grout sponge or a rag. Spray lubricants are not required on the guide rail or wheels.
6. Clean the water pan by spraying with a hose or wiping with a grout sponge.

Use only mild soap and a damp cloth to clean the tool. Many household cleaners contain chemicals which could seriously damage plastic. Also, do not use gasoline, turpentine, lacquer or paint thinner, dry cleaning fluids or similar products. Try not to let any liquid get inside the tool; never immerse any part of the tool into a liquid.

Lubrication

▲ WARNING: NEVER spray or in any other way apply lubricants or cleaning solvents inside the tool. This can seriously affect the life and performance of the tool and may result in personal injury.

DEWALT tools are properly lubricated at the factory and are ready for use. However, it is recommended that, once

FIG. 19

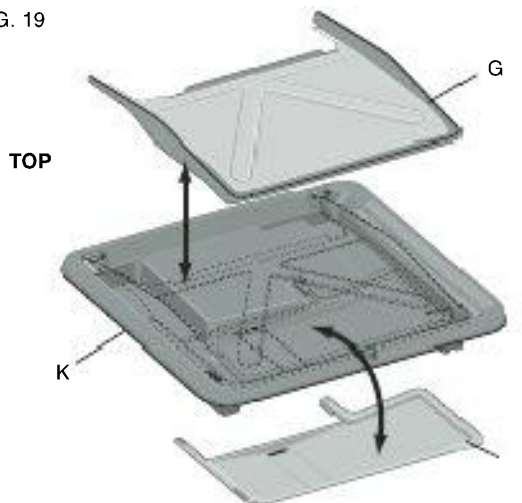

FIG. 20

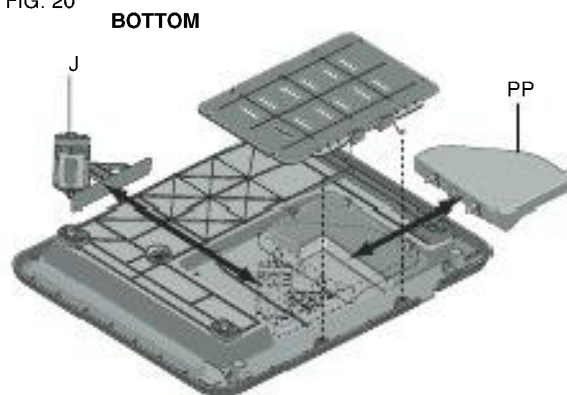

FIG. 21



a year, you take or send the tool to a certified service center for a thorough cleaning and inspection.

Repairs

To assure product SAFETY and RELIABILITY, repairs, maintenance and adjustment (including brush inspection and replacement) should be performed by authorized service centers or other qualified service organizations, always using identical replacement parts.

ACCESSORIES

Recommended accessories for use with your tool are available at extra cost from your local dealer or authorized service center.

▲ CAUTION: The use of any other accessory not recommended for use with this tool could be hazardous.

STAND D24001 (FIG. 21)

CUTTING WHEELS:	7"	Ceramic	DW4760
	10"	Ceramic	DW4761
	10"	Porcelain	DW4762

If you need assistance in locating any accessory for your tool, contact: DEWALT Industrial Tool Co., 701 East Joppa Road, Baltimore, MD 21286 (1-800-4-DEWALT).

Three Year Limited Warranty

DEWALT will repair, without charge, any defects due to faulty materials or workmanship for three years from the date of purchase. This warranty does not cover part failure due to normal wear or tool abuse. For further detail of warranty coverage and warranty repair information, visit www.dewalt.com or call 1-800-4-DEWALT (1-800-433-9258). This warranty does not apply to accessories or damage caused where repairs have been made or attempted by others. This warranty gives you specific legal rights and you may have other rights which vary in certain states or provinces.

In addition to the warranty, DEWALT tools are covered by our:

1 YEAR FREE SERVICE

DEWALT will maintain the tool and replace worn parts caused by normal use, for free, any time during the first year after purchase.

90 DAY MONEY BACK GUARANTEE

If you are not completely satisfied with the performance of your DEWALT Power Tool, Laser, or Nailer for any reason, you can return it within 90 days from the date of purchase with a receipt for a full refund – no questions asked.

FREE WARNING LABEL REPLACEMENT: If your warning labels (also refer to pages 3, 4) become illegible or are missing, call 1-800-4-DEWALT for a free replacement.

Troubleshooting Guide

BE SURE TO FOLLOW SAFETY RULES AND INSTRUCTIONS

MANY COMMON PROBLEMS CAN BE SOLVED EASILY BY UTILIZING THE CHART BELOW. FOR MORE SERIOUS OR PERSISTENT PROBLEMS, CONTACT A DeWALT SERVICE CENTER OR CALL 1-(800)-4-DeWALT.

TROUBLE! SAW WILL NOT START WHAT'S WRONG?

1. Saw not plugged in
2. GFCI tripped
3. Saw will not run (plugged in; switch on)
4. Fuse blown or circuit breaker tripped
5. Cord damaged
6. Brushes worn out

WHAT TO DO...

1. Plug in saw.
2. Push switch to off and push reset button on GFCI.
3. Push switch to off and push the reset button on the GFCI.
4. Push switch to off and replace fuse or reset circuit breaker.
5. Have cord replaced by authorized service center.
6. Have brushes replaced by authorized service center.

TROUBLE! SAW MAKES UNSATISFACTORY CUTS WHAT'S WRONG?

1. Dull cutting wheel
2. Water pump will not pump water
3. Cutting wheel mounted backwards
4. Build up on cutting wheel
5. Incorrect cutting wheel for work being done

WHAT TO DO...

1. Replace cutting wheel. See page 6.
2. Remove water pump and spray with clean water to dislodge the impeller
3. Turn cutting wheel around. See page 6.
4. Use dressing stone to remove build up.
5. Change the cutting wheel. See page 6.

TROUBLE! CUTTING WHEEL DOES NOT COME UP TO SPEED WHAT'S WRONG?

1. Extension cord too small of a wire gauge or too long
2. Arbor loose
3. Low house voltage

WHAT TO DO...

1. Replace with adequate size cord. See page 2.
2. Tighten arbor
3. Contact your electric company.

TROUBLE! MACHINE VIBRATES EXCESSIVELY WHAT'S WRONG?

1. Saw not mounted securely to stand
2. Stand or bench on uneven floor
3. Damaged saw cutting wheel

WHAT TO DO...

1. Reposition water pan on stand.
2. Reposition on flat level surface.
3. Replace cutting wheel. See page 6.

TROUBLE! DOES NOT MAKE ACCURATE CUTS WHAT'S WRONG?

1. Edge guide not secure to fence
2. Cutting wheel is not square to fence
3. Cutting wheel is not perpendicular to cart surface
4. Workpiece moving

WHAT TO DO...

1. Check and adjust. See page 7.
2. Check and adjust. See page 9.
3. Check and adjust fence. See page 9.
4. Use edge guide.

SI VOUS AVEZ DES QUESTIONS OU VOUS VOULEZ NOUS FAIRE PART DE VOS COMMENTAIRES CONCERNANT CET OUTIL OU TOUT AUTRE OUTIL DEWALT, COMPOSEZ SANS FRAIS LE : 1 800 433-9258 (1-800-4-DEWALT)

Ce produit est couvert sous le brevet américain no D486,165 et autres brevets en instance.

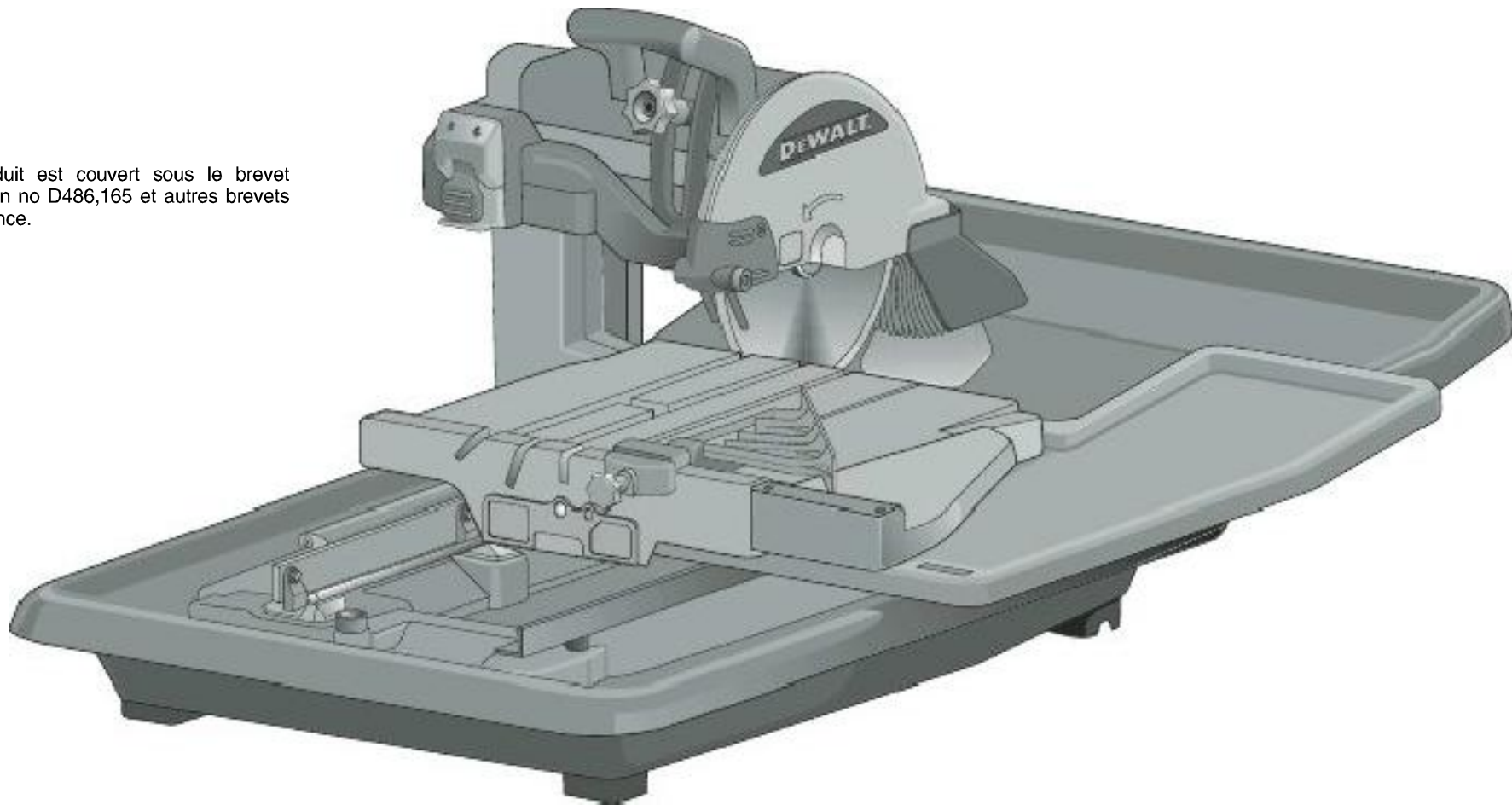

Français

DEWALT... DE CONCEPTION ROBUSTE POUR LE CHANTIER

Les outils industriels à haut rendement DEWALT sont conçus pour les applications industrielles et de construction les plus exigeantes en Amérique du Nord. La conception de chaque outil de cette gamme — depuis les perceuses jusqu'aux ponceuses et aux meules — est le fruit d'essais rigoureux, non seulement en chantier mais aussi dans tous les secteurs industriels. Chaque outil est fabriqué avec soin et précision par des systèmes de fabrication avancés et subit un strict contrôle de la qualité. Chacun d'eux est examiné attentivement avant de quitter l'usine afin d'en assurer la conformité aux exigences de durabilité, de fiabilité et d'efficacité requises par le client.

DEWALT De conception robuste pour le chantierGARANTIE.

TABLE DES MATIÈRES

CONSIGNES DE SÉCURITÉ IMPORTANTES CONCERNANT TOUS LES OUTILS.....	14	NETTOYAGE	23
DIRECTIVES CONCERNANT LA MISE À LA TERRE	14	LUBRIFICATION.....	23
CONSIGNES DE SÉCURITÉ ADDITIONNELLES CONCERNANT LE COUPE-TUILE À L'EAU	15	RÉPARATIONS.....	23
GUIDE DE DÉMARRAGE.....	17	ACCESSOIRES.....	24
COMPOSANTS	19	GARANTIE.....	24
ASSEMBLAGE	19	GUIDE DE DÉPANNAGE.....	25
CARACTÉRISTIQUES TECHNIQUES.....	20		
FONCTIONNEMENT.....	20		
MISE EN PLACE DE L'OUTIL.....	20		
MOTEUR.....	20		
INTERRUPTEUR MARCHE-ARRÊT	20		
BUSES D'EAU	20		
ALIGNEMENT DE LA LAME	20		
PROFONDEUR DE LA LAME.....	20		
RÉALISATION D'UNE COUPE	21		
VERROUILLAGE DE L'ÉTABLI DE COUPE	21		
TYPES DE COUPES.....	21		
RÉGLAGES	22		
ENTRETIEN.....	23		
BALAIS.....	23		
TRANSPORT ET RANGEMENT.....	23		

Consignes de sécurité importantes concernant tous les outils

AVERTISSEMENT : Afin de travailler en toute sécurité et d'éviter les risques de blessure ou d'endommager sérieusement la scie, lire attentivement le manuel d'utilisation avant d'utiliser l'outil. Lors de l'entretien de l'outil, n'utiliser que des pièces de rechange identiques. Faire remplacer les cordons endommagés par un centre de service autorisé.

DIRECTIVES CONCERNANT LA MISE À LA TERRE

- En cas de défaillance technique ou de panne, la mise à la terre offre un chemin de moindre résistance au courant électrique pour réduire tout risque de choc électrique. Cet outil est pourvu d'un cordon électrique muni d'un conducteur de protection et d'une fiche de mise à la terre. Cette fiche doit être branchée dans prise adéquate installée correctement et mise à la terre conformément aux codes et réglementations locales.
- Ne pas modifier la fiche fournie avec l'appareil. Si elle ne rentre pas dans la prise, faire installer une prise adéquate par un électricien qualifié.
- Tout branchement non conforme du conducteur de protection augmente les risques de choc électrique. Le conducteur dont la surface externe d'isolation est verte avec ou sans rayures jaunes est le conducteur de protection. En cas de réparation ou de remplacement du cordon électrique ou de la fiche, Ne jamais connecter le conducteur de protection à une borne sous tension.
- Si les Directives de mise à la terre ne sont pas complètement comprises ou si on n'est pas sûr que l'appareil est correctement mis à la terre, faire appel à un électricien qualifié ou à du personnel d'entretien.
- N'utiliser que des rallonges trifilaires munies de fiches tripolaires et des prises tripolaires acceptant la fiche de l'outil.
- Réparer ou remplacer immédiatement tout cordon endommagé ou usé.

Cet outil doit être mis à la terre afin de protéger l'utilisateur contre les risques de choc électrique. Cet outil est doté d'un cordon trifilaire et d'une fiche de terre à trois broches; on doit en raccorder la fiche dans une prise murale appropriée. Le conducteur vert (ou vert et jaune) du cordon est le fil de mise à la terre. Ne jamais raccorder le fil vert (ou vert et jaune) à une borne sous tension. Les outils destinés à être raccordés à un circuit d'alimentation électrique ayant une tension nominale de moins de 150 volts sont en effet munis d'une fiche qui est semblable à celle illustrée à la figure A, alors que ceux destinés à être raccordés à un circuit dont la tension nominale varie entre 150 et 250 volts sont munis d'une fiche qui ressemble à celle illustrée à la figure D. On peut utiliser un adaptateur, comme celui illustré aux figures B et C, pour brancher la fiche de l'outil (figure A) à une prise à deux broches. On doit mettre cet adaptateur à la terre en en reliant l'oeillet, la cosse ou tout autre dispositif de couleur verte à un élément mis à la terre de manière permanente, comme une boîte à prises bien mise à la terre. Aucun adaptateur n'est disponible pour une fiche semblable à celle illustrée à la figure D. IL EST CEPENDANT INTERDIT DE SE SERVIR D'UN TEL ADAPTATEUR (FIGURES B ET C) AU CANADA.

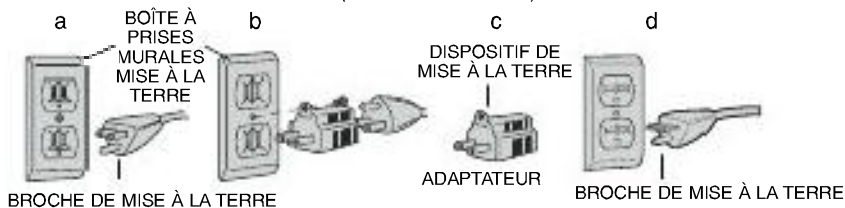

AVERTISSEMENT : Afin de réduire les risques d'électrocution, s'assurer que tous les raccords sont secs et dégagés du sol.

AVERTISSEMENT : Le cordon d'alimentation de la scie est muni d'un disjoncteur de fuite de terre (GFCI) afin d'offrir une protection additionnelle. Lorsqu'on utilise une rallonge, on doit enficher le disjoncteur dans la source d'alimentation électrique avant de la rallonge.

AVERTISSEMENT : La pompe à eau doit être enfichée dans une prise protégée par un disjoncteur de fuite de terre.

REMARQUE : Ne pas faire fonctionner la pompe à sec.

AVERTISSEMENT : Effectuer un essai du disjoncteur de fuite de terre avant chaque utilisation en :

- enfichant le disjoncteur dans la prise de courant pour allumer le voyant rouge;
- enfonçant le poussoir d'essai pour éteindre le voyant rouge;
- enfonçant le bouton de réenclenchement avant d'utiliser l'outil; ne pas l'utiliser si l'essai a échoué.

MISE EN GARDE : LORS DE L'ENTRETIEN, N'UTILISER QUE DES PIÈCES DE RECHANGE IDENTIQUES. Faire réparer ou remplacer les cordons endommagés. Toujours remplacer le cordon par un cordon muni d'un disjoncteur de fuite de terre.

AVERTISSEMENT : Ne jamais utiliser la scie avec de l'eau salée ou un fluide conducteur.

AVERTISSEMENT : Lorsqu'on utilise un outil électrique, on doit suivre les consignes de sécurité élémentaires, y compris les directives indiquées aux présentes, afin d'éviter les risques d'incendie, de choc électrique et de blessure.

- GARDER LES DISPOSITIFS DE PROTECTION EN PLACE** et en bon état de fonctionnement.
- RETIRER LES CLÉS DE RÉGLAGE** ; prendre l'habitude de s'assurer que les clés de réglage sont retirées de l'outil avant de le démarrer.
- GARDER L'AIRE DE TRAVAIL PROPRE** ; les espaces de travail et les établis encombrés sont propices aux blessures.
- UTILISER L'OUTIL DANS DES ENDROITS APPROPRIÉS** ; ne pas exposer l'outil à la pluie ou à la neige, ni l'utiliser dans des endroits humides ou mouillés. Garder l'aire de travail bien éclairée.
- TENIR LES ENFANTS À L'ÉCART** ; s'assurer que personne ne s'approche de l'aire de travail.
- S'ASSURER QUE L'ATELIER EST SÛR POUR LES ENFANTS**; utiliser des cadenas, des interrupteurs centraux ou enlever les commandes de démarrage.
- NE PAS FORCER L'OUTIL** ; pour obtenir de meilleurs résultats et prévenir les risques de blessure, laisser l'outil couper à la vitesse pour laquelle il a été conçu.
- UTILISER L'OUTIL APPROPRIÉ** ; ne pas forcer l'outil ou l'accessoire, ni l'utiliser pour des travaux autres que ceux pour lesquels il a été conçu.
- UTILISER LES RALLONGES APPROPRIÉES** ; s'assurer que la rallonge électrique est en bon état et qu'elle est en mesure de porter le courant nécessaire à l'outil. Une rallonge de calibre inférieur entraînera une chute de tension se traduisant par une perte de puissance et une surchauffe. Le tableau ci-dessous illustre les calibres que l'on doit utiliser selon la longueur de la rallonge et l'intensité nominale indiquée sur la plaque signalétique. En cas de doute, utiliser le calibre suivant. Plus le calibre est petit, plus la rallonge peut porter de courant.

Calibre minimal des rallonges

Tension	Longueur totale de la rallonge en mètres			
120 V	de 0 à 7,6	de 7,6 à 15,2	de 15,2 à 30,4	de 30,4 à 45,7
Intensité nominale (en amperes)				
Plus de	Pas plus de	Calibre AWG		
12	16	14	12	Non recommandé

- PORTER DES VÊTEMENTS APPROPRIÉS** ; ne pas porter de vêtements amples ni de gants, de cravate, de bague, de bracelet ou d'autres bijoux, car ceux-ci peuvent rester coincés dans les pièces mobiles. On recommande le port de chaussures antidérapantes. Couvrir ou attacher les cheveux longs. Se tenir éloigné des événements puisque ces derniers pourraient camoufler des pièces mobiles.
- TOUJOURS PORTER DES LUNETTES DE SÉCURITÉ** ; porter aussi un masque facial ou un masque anti-poussières lorsqu'on soulève de la poussière. Les lunettes