

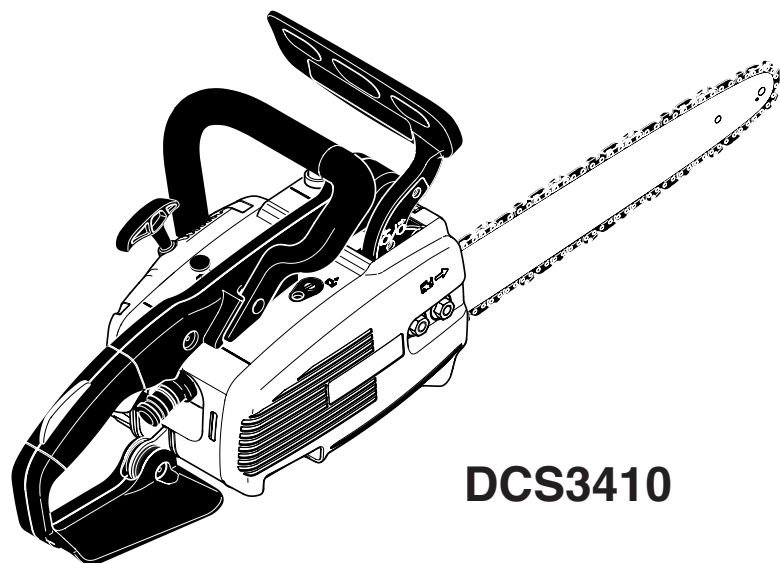

Spare Parts List
Ersatzteilliste
Liste de pièces détachées
Lista de piezas de repuesto

2006-07



DCS3410

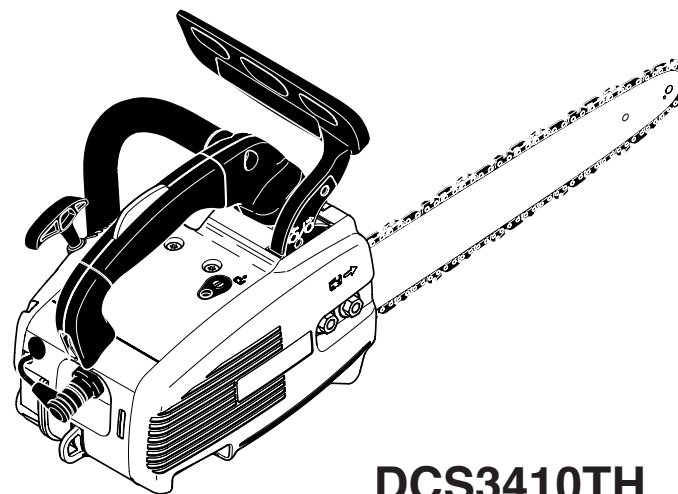

DCS3410TH

995 700 546 (DE, GB, FR, ES)

DCS3410
DCS3410TH

1

Tank, Kettenbremse
Tank, chain brake
Réservoir, frein de chaîne
Depósito, freno de cadena

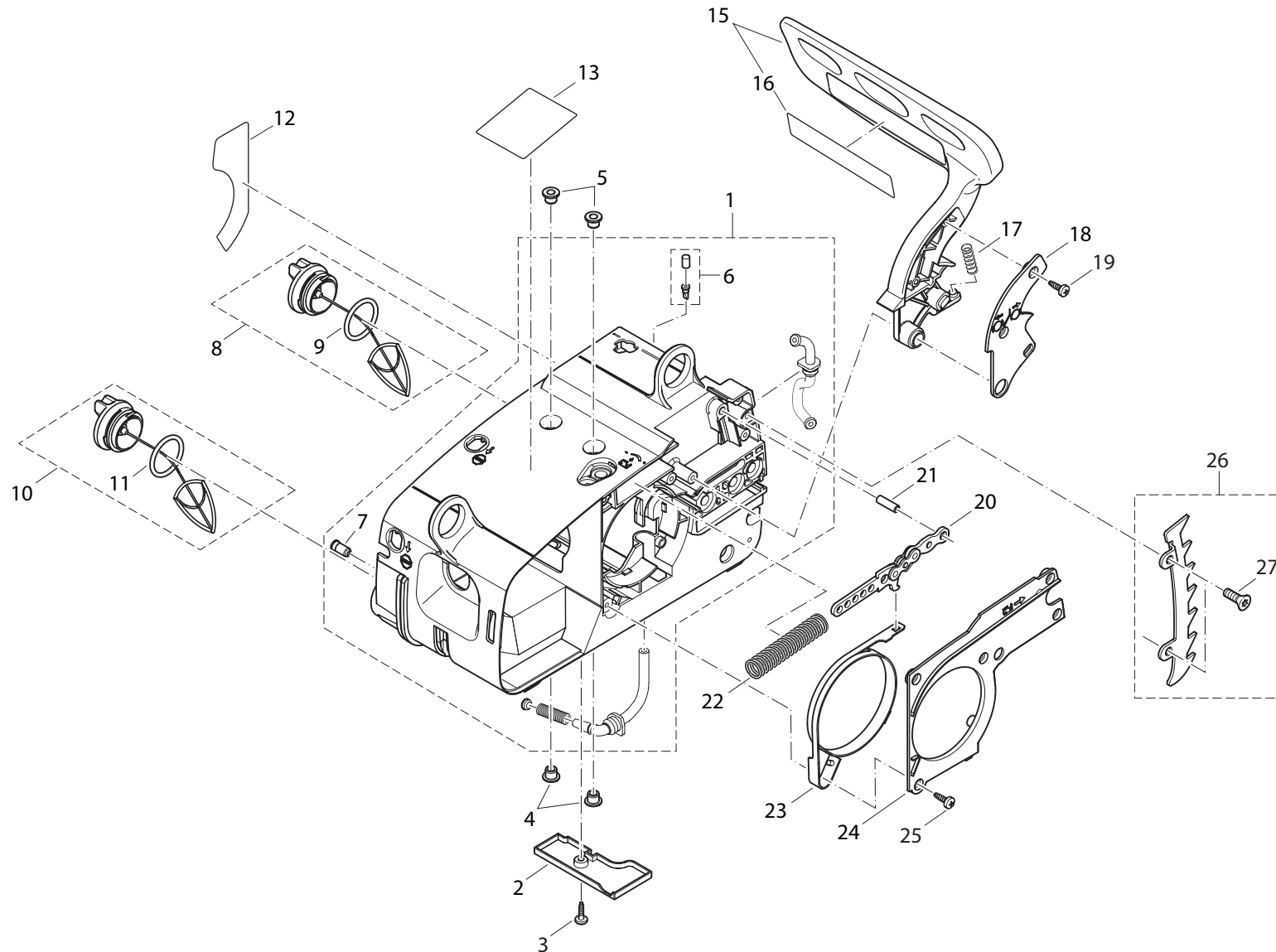

DCS3410
DCS3410TH



Seite / Page	Pos.	DCS3410	DCS3410TH	Teil-Nr. Part No. No. de pièce No. de pieza	Hinweise Notes Renseign. Nota	Bezeichnung	Spezifikation Specification	Description	Désignation	Denominación
1	1	1	1	170 111 602		MOTORTRÄGER KPL. GRAU		ENGINE HOUSING, CPL., GREY	SUPPORT DE MOTEUR CPL. GRIS	SOPORTE DE MOTOR CPL. GRIS
1	2	1	1	170 111 680		ABDECKUNG ÖLSAUGLEITUNG BLAU		COVER, BLUE	COUVERCLE BLEU	CUBIERTA AZUL
1	3	1	1	915 735 100		KREUZSCHLITZ-KUNSTSTOFFSCHRAUBE	3,5x10	SCREW	VIS	TORNILLO
1	4	2	2	170 111 050		BUCHSE		BUSHING	DOUILLE	CASQUILLO
1	5	2	2	170 111 050		BUCHSE		BUSHING	DOUILLE	CASQUILLO
1	6	1	1	170 175 010		SATZ BELÜFTUNGSVENTIL		VENT VALVE SET	SOUPAPE D' AÉRATION JEU	VÁLVULA VENTILACIÓN JUEGO
1	7	1	1	010 245 030		BELÜFTUNGSVENTIL		VENT VALVE	SOUPAPE D' AÉRATION	VÁLVULA VENTILACIÓN
1	8	1	1	170 114 061		TANKDECKEL KPL.		TANK CAP CPL.	BOUCHON RESERVOIR CPL.	TORNILLO DE CIERRE CPL.
1	9	1	1	963 225 030		O-RING		PACKING RING	BAGUE-JOINT	ANILLO DE GUARNICION
1	10	1	1	170 114 061		TANKDECKEL KPL.		TANK CAP CPL.	BOUCHON RESERVOIR CPL.	TORNILLO DE CIERRE CPL.
1	11	1	1	963 225 030		O-RING		PACKING RING	BAGUE-JOINT	ANILLO DE GUARNICION
1	12	1	1	980 114 904		AUFKLEBER	CHOKE	LABEL	PLAQUE	CALCOMANIA
1	13		1	980 114 919		AUFKLEBER	TopHandle	LABEL	PLAQUE	CALCOMANIA
1	13	1	1	980 115 369		AUFKLEBER	Kickback	LABEL	PLAQUE	CALCOMANIA
1	15	1	1	170 213 020		HANDSCHUTZ KPL.	EU	HAND GUARD CPL.	PROTÈGE-MAIN CPL.	PROTECTOR DE MANO CPL.
1	16	1	1	980 114 237		AUFKLEBER HANDSCHUTZ		LABEL	PLAQUE	CALCOMANIA
1	17	1	1	225 213 060		FEDER FÜR HANDSCHUTZ		SPRING	RESSORT	MUELLE
1	18	1	1	170 213 040		ABDECKUNG HANDSCHUTZ		COVER	COUVERCLE	CUBIERTA
1	19	2	2	915 735 100		KREUZSCHLITZ-KUNSTSTOFFSCHRAUBE	3,5x10	SCREW	VIS	TORNILLO
1	20	1	1	028 213 532		BREMSBANDHALTER KPL.		BRAKE SPRING HOLDER CPL.	SUPPORT DE RESSORT DE FREIN CPL.	SOPORTE DE CINTA DE FRENO CPL.
1	21	1	1	962 650 200		NADELROLLE	ø5x20	CYLINDRICAL PIN	GOUILLE CYLINDRIQUE	PRISIONERO
1	22	1	1	028 213 521		SPEICHERFEDER		SPRING	RESSORT	MUELLE
1	23	1	1	170 213 080		BREMSBAND		BRAKE SPRING	RESSORT DE FREIN	CINTA DE FRENO
1	24	1	1	170 213 050		ABDECKPLATTE KETTENBREMSE		COVER	COUVERCLE	CUBIERTA
1	25	5	5	915 735 100		KREUZSCHLITZ-KUNSTSTOFFSCHRAUBE	3,5x10	SCREW	VIS	TORNILLO
1	26	1	1	170 250 200		ZACKENLEISTE KPL.		SPIKE BAR CPL.	BARRE DENTÉE CPL.	BARRA DENTADA CPL.
1	27	2	2	913 850 155		INNENSTERN-SENKKOPF-SCHRAUBE	5x15	SCREW	VIS	TORNILLO

DCS3410
DCS3410TH

2

Zylinder, Luftfilter, Schalldämpfer
Cylinder, air filter, muffler
Cylindre, filtre à air, pot d' échappement
Cilindro, filtro de aire, silencioso

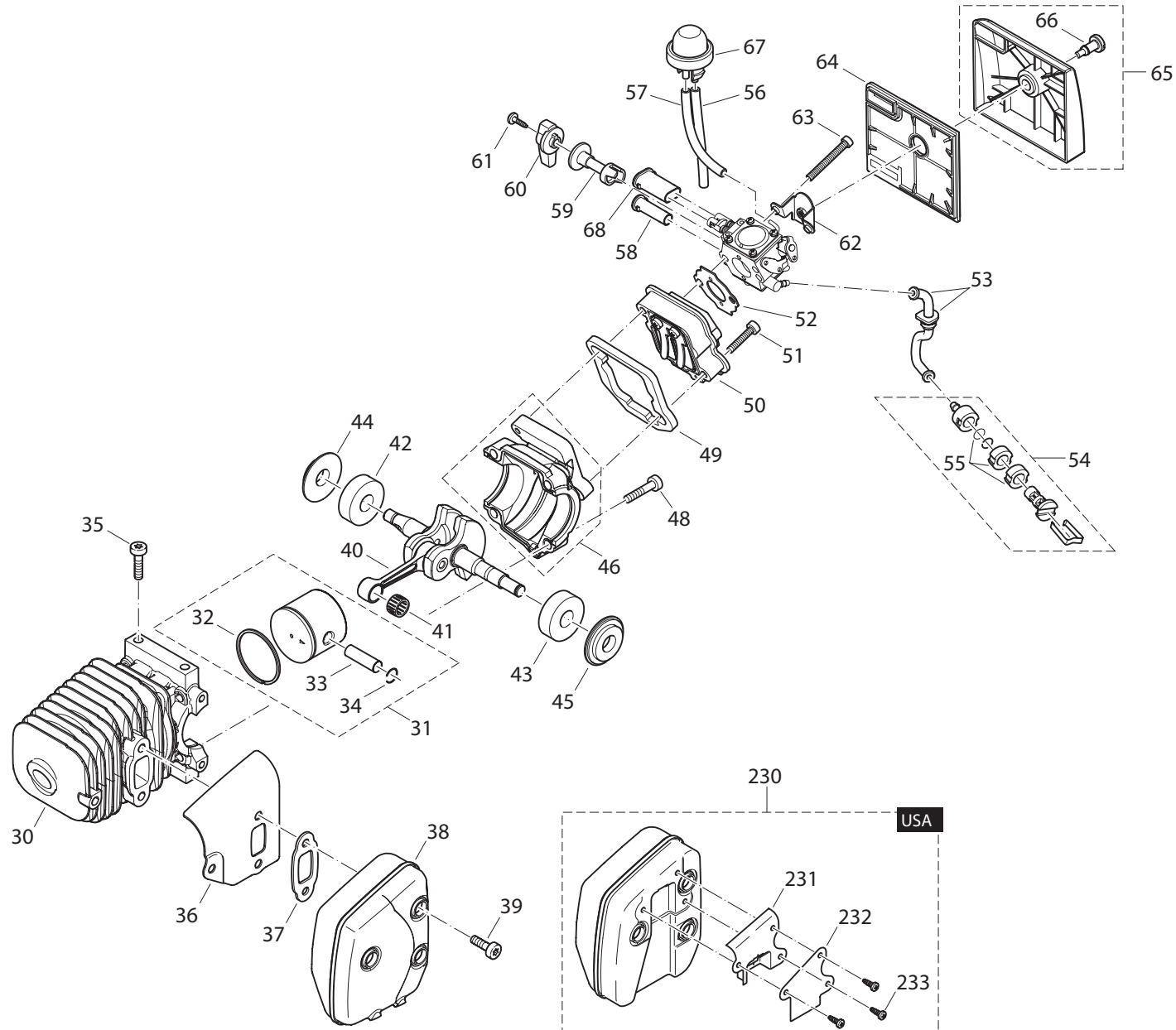

DCS3410
DCS3410TH



Seite / Page	Pos.	DCS3410	DCS3410TH	Teil-Nr. Part No. No. de pièce No. de pieza	Hinweise Notes Renseign. Nota	Bezeichnung	Spezifikation Specification	Description	Désignation	Denominación
2	30	1	1	170 131 010		ZYLINDER		CYLINDER	CYLINDRE	CILINDRO
2	31	1	1	170 132 100		KOLBEN KPL.		PISTON CPL.	PISTON CPL.	PISTÓN CPL.
2	32	1	1	170 132 030		KOLBENRING		PISTON RING	SEGMENT DE PISTON	SEGMENTO DE PISTÓN
2	33	1	1	170 132 020		KOLBENBOLZEN		PISTON PIN	AXE DE PISTON	PERNO DE PISTÓN
2	34	2	2	170 132 040		C-RING		SPRING RING	ANNEAU-RESSORT	ANILLO ELÁSTICO
2	35	4	4	908 005 205		INNENSTERN-SCHRAUBE	5x20	SCREW	VIS	TORNILLO
2	36	1	1	170 174 081		LEITBLECH		HEAT SHIELD	TÔLE DE PROTECTION	CHAPA DEFLECTORA
2	37	1	1	170 174 050		DICHTUNG SCHALLDÄMPFER		GASKET	JOINT	JUNTA
2	38	1	1	170 174 100		SCHALLDÄMPFER KPL.	EU/J	MUFFLER	POT D' ÉCHAPPEMENT	SILENCIOSO
2	230	1	1	170 174 200		SCHALLDÄMPFER KPL.	USA	MUFFLER	POT D' ÉCHAPPEMENT	SILENCIOSO
2	231	1	1	170 174 120		FUNKENSCHUTZSIEB KPL.	USA	SPARK ARRESTOR SCREEN	TAMIS	TAMIZ
2	232	1	1	170 174 110		ABDECKUNG	USA	COVER	COUVERCLE	CUBIERTA
2	233	3	3	914 535 105		BLECHSCHRAUBE	3,5X9,5	SCREW	VIS	TORNILLO
2	39	3	3	908 405 145		INNENSTERN-SCHRAUBE	5x14	SCREW	VIS	TORNILLO
2	40	1	1	170 120 100		KURBELWELLE KPL.		CRANKSHAFT CPL.	VILEBREQUIN CPL.	CIGÜEÑAL CPL.
2	41	1	1	962 211 006		KOLBENBOLZENLAGER	8x11x10	NEEDLE CAGE	CAGE À AIGUILLES	JAULA DE AGUJAS
2	42	1	1	960 102 129		KUGELLAGER	6201	BALL BEARING	ROULEMENT À BILLES	RODAMIENTO
2	43	1	1	960 102 129		KUGELLAGER	6201	BALL BEARING	ROULEMENT À BILLES	RODAMIENTO
2	44	1	1	962 900 060		RADIALDICHTUNG		RADIAL RING	JOINT RADIAL	ANILLO RADIAL
2	45	1	1	962 900 060		RADIALDICHTUNG		RADIAL RING	JOINT RADIAL	ANILLO RADIAL
2	46	1	1	170 111 200		KURBELGEHÄUSE KPL.		CRANKCASE CPL.	CARTER-COTÉ	CÁRTER CIGÜEÑAL
2	48	4	4	908 005 205		INNENSTERN-SCHRAUBE	5x20	SCREW	VIS	TORNILLO
2	49	1	1	170 131 040		SCHAUMSTOFFDICHTUNG		GASKET	JOINT	JUNTA
2	50	1	1	170 131 100		ZWISCHENFLANSCH KPL.		INTERMEDIATE FLANGE CPL.	BRIDE INTERMÉDIAIRE	BRIDA INTERMEDIA
2	51	2	2	913 340 204		INNENSTERN-SCHLITZ-SCHRAUBE	4x20	SCREW	VIS	TORNILLO
2	52	1	1	965 524 023		DICHTUNG FÜR VERGASERFLANSCH		GASKET	JOINT	JUNTA
2	53	1	1	170 114 070		KRAFTSTOFFSCHLAUCH		FUEL LINE	CONDUITE CARBURANT	CONDUCTO COMBUSTIBLE
2	54	1	1	010 114 010		SAUGKOPF KPL.		SUCTION HEAD	TETE D'ASPIRATION	CABEZA DE ASPIRACION
2	55	1	1	010 114 020		REPARATUR-SATZ, FILTER (JE 5 STCK.)		REP. KIT, FILTER (5 OF EACH)	JEU DE RÉPARAT., FILTRE	JUEGO DE REPARAR, FILTRO
2	56	m	m	965 452 380		IMPULSSCHLAUCH	L=65 MM	TUBE	GAINÉ	TUBO
2	57	m	m	965 452 080		VITONSCHLAUCH	L=55 MM	TUBE	GAINÉ	TUBO
2	58	1	1	170 118 041		FÜHRUNG	S	ADJUSTING GUIDE	GUIDAGE D' AJUSTAGE	GUÍA DE AJUSTE
2	59	1	1	170 155 050		CHOKEHEBELSTANGE		CHOKE LINKAGE	TRINGLE DE STARTER	VARILLAS ESTRANGUL. AIRE
2	60	1	1	170 155 040		CHOKEHEBEL		CHOKE LEVER	LEVIER DE STARTER	PALANCA ESTRANGUL. AIRE

DCS3410
DCS3410TH



Seite / Page	Pos.	DCS3410	DCS3410TH	Teil-Nr. Part No. No. de pièce No. de pieza	Hinweise Notes Renseign. Nota	Bezeichnung	Spezifikation Specification	Description	Désignation	Denominación
2	61	1	1	915 735 100		KREUZSCHLITZ-KUNSTSTOFFSCHRAUBE	3,5x10	SCREW	VIS	TORNILLO
2	62	1	1	170 151 051		BEFESTIGUNG FÜR LUFTFILTERDECKEL		AIR FILTER COVER MOUNTING	FIXATION	FIJACIÓN
2	63	2	2	908 004 405		INNENSTERN-SCHRAUBE	4x40	SCREW	VIS	TORNILLO
2	64	1	1	170 173 021		LUFTFILTER	VLIES	AIR FILTER	FILTRE À AIR	FILTRO DE AIRE CPL.
2	65	1	1	170 118 100		LUFTFILTERDECKEL KPL.		COVER	CAPOT	CUBIERTA
2	66	1	1	170 118 020		SCHRAUBE FÜR DECKEL		SCREW	VIS	TORNILLO
2	67	1	1	010 155 010		PRIMER		PRIMER	POMPE À CARBURANT	BOMBA DE COMBUSTIBLE
2	68	1	1	170 118 031		FÜHRUNG	H / L	ADJUSTING GUIDE	GUIDAGE D' AJUSTAGE	GUÍA DE AJUSTE

DCS3410
DCS3410TH

3

Ölpumpe, Kupplung
Öil pump, clutch
Pompe à huile, embrayage
Bomba de aceite, embrague

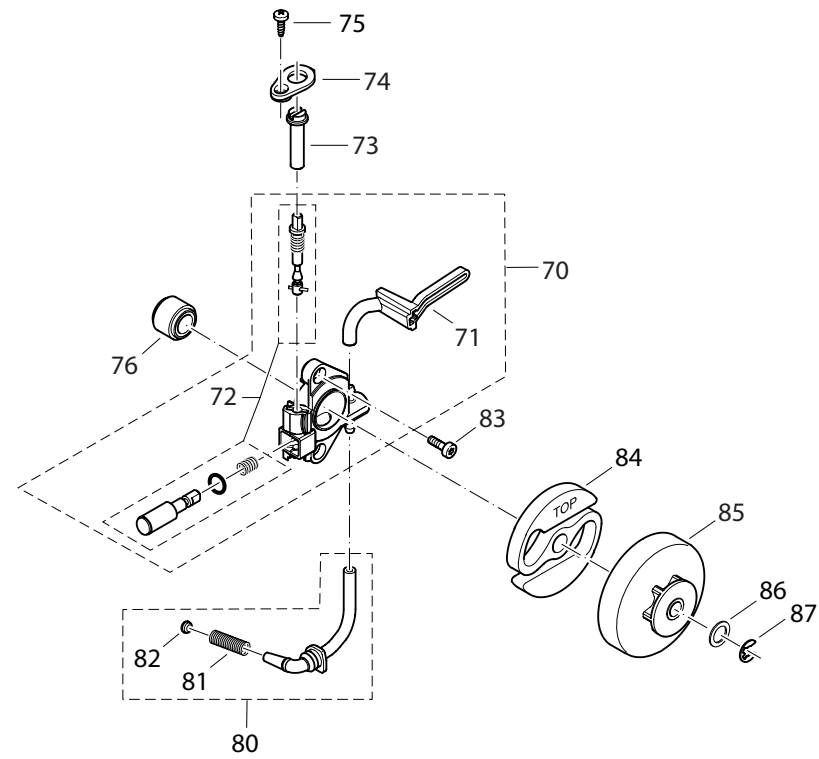

DCS3410
DCS3410TH



Seite / Page	Pos.	DCS3410	DCS3410TH	Teil-Nr. Part No. No. de pièce No. de pieza	Hinweise Notes Renseign. Nota	Bezeichnung	Spezifikation Specification	Description	Désignation	Denominación
3	70	1	1	170 245 100		ÖLPUMPE KPL.		OIL PUMP CPL.	POMPE À HUILE CPL.	BOMBA DE ACEITE CPL.
3	71	1	1	170 245 110		ÖLDRUCKLEITUNG		OIL LINE	CONDUITE HUILE	TUBO ACEITE
3	72	1	1	170 245 300		REPARATURSATZ ÖLPUMPE		REPAIR KIT	JEU DE RÉPARATION	JUEGO DE REPARAR
3	73	1	1	170 245 030		EINSTELLHEBEL		ADJUSTING LEVER	LEVIER DE RÉGLAGE	PALANCA DE REGLAJE
3	74	1	1	170 245 090		ABDECKUNG FÜR EINSTELLSCHRAUBE		COVER	COUVERCLE	CUBIERTA
3	75	1	1	915 735 100		KREUZSCHLITZ-KUNSTSTOFFSCHRAUBE	3,5x10	SCREW	VIS	TORNILLO
3	76	1	1	170 245 130		SCHNECKE		PUMP DRIVE	LE COMMANDE DE POMPE	PROPULSOR DE LA BOMBA
3	80	1	1	170 245 200		ÖLSAUGLEITUNG KPL.		SUCTION LINE OIL CPL.	CONDUITE D'ASPIR. HUILE CPL.	CONDUCTO DE ASPIR. ACEITE CPL.
3	81	1	1	021 245 060		DRUCKFEDER		SPRING	RESSORT	MUELLE
3	82	1	1	021 245 100		STOPFEN		PLUG	BOUCHON	TOPE DE CIERRE
3	83	2	2	908 004 125		INNENSTERN-SCHRAUBE	4x12	SCREW	VIS	TORNILLO
3	84	1	1	170 181 010		KUPPLUNGSLAMELLE		CLUTCH	EMBRAYAGE	EMBRAGUE
3	85	1	1	170 223 100		KUPPLUNGSTROMMEL KPL.		CLUTCH DRUM CPL.	TAMBOUR CPL.	TAMBOR CPL.
3	86	1	1	900 006 065		PASS-SCHEIBE	8x14x1	DISC	DISQUE	ARANDELA
3	87	1	1	927 306 000		SICHERUNGSSCHEIBE	ø6	SAFETY DISC	DISQUE SÉCURITÉ	ARANDELA SEGURIDAD

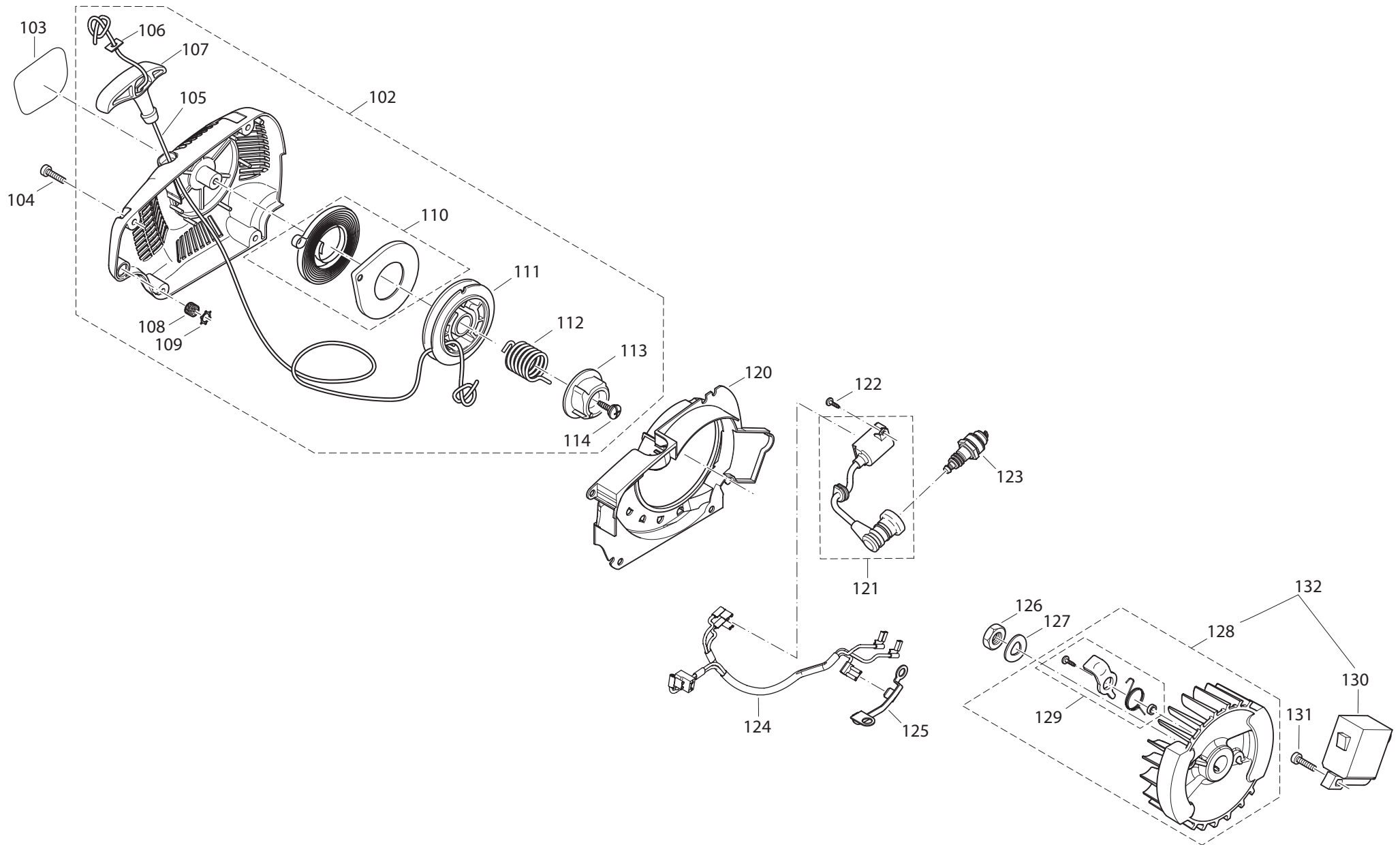

**DCS3410
DCS3410TH**



Seite / Page	Pos.	DCS3410	DCS3410TH	Teil-Nr. Part No. No. de pièce No. de pieza	Hinweise Notes Renseign. Nota	Bezeichnung	Spezifikation Specification	Description	Désignation	Denominación
4	102	1	1	170 160 650		STARTER KPL. BLAU		STARTER ASSY., BLUE	DISPOS. DE DÉMARRAGE CPL. BLEU	DISPOS. DE ARRANQUE CPL. AZUL
4	103	1	1	980 114 909		AUFKLEBER VENTILATORGEHÄUSE	MAKITA	LABEL	PLAQUE	CALCOMANIA
4	104	4	4	913 340 204		INNENSTERN-SCHLITZ-SCHRAUBE	4x20	SCREW	VIS	TORNILLO
4	105	1	1	021 164 010		ANWERFSEIL	Ø3 X 900 MM	STARTER ROPE	CÂBLE DE DÉMARRAGE	CORDÓN DE ARRANQUE
4	105	1	1	985 000 150	ACC.	ANWERFSEIL	Ø3 X 100 M	STARTER ROPE	CÂBLE DE DÉMARRAGE	CORDÓN DE ARRANQUE
4	106	1	1	021 245 020		SCHEIBE		WASHER	DISQUE	ARANDELA
4	107	1	1	170 160 760		ANWERFGRIFF		STARTER GRIP	POIGNEE DE LANCEMENT	TIRADOR DE ARRANQUE
4	108	1	1	965 404 840		DICHTUNG	Ø16	GASKET	JOINT	JUNTA
4	109	1	1	930 216 030		ZACKENRING	ZJ16	TOOTHED WASHER	RONDELLE DENTELLEE	ARANDELA DENTADA
4	110	1	1	170 160 730		STARTERFEDER KPL.		REWIND SPRING	RESSORT DE RAPPEL	RESORTE RETENCIÓN
4	111	1	1	170 160 740		SEILTROMMEL		CABLE DRUM	TAMBOUR DE CÂBLE	TAMBOUR PARA CORDÓN
4	112	1	1	170 160 770		FEDER		SPRING	RESSORT	MUELLE
4	113	1	1	170 160 780		MITNEHMER		STARTER WHEEL	ROUE DÉCLENCHÉUR	RUEDA DE ARRANQUE
4	114	1	1	170 160 790		SCHRAUBE		SCREW	VIS	TORNILLO
4	120	1	1	170 160 620		LUFTFÜHRUNG BLAU		AIR DUCT, BLUE	PLAQUE DE VENTILATION BLEU	PLACA VENTILACIÓN AZUL
4	121	1	1	170 143 041		ZÜNDSPULE KPL.		IGNITION COIL	BOBINE D' ALLUMAGE	BOBINA DE ENCENDIDO
4	122	2	2	915 735 100		KREUZSCHLITZ-KUNSTSTOFFSCHRAUBE	3,5x10	SCREW	VIS	TORNILLO
4	123	1	1	965 603 021		ZÜNDKERZE		SPARK PLUG	BOUGIE	BUIJA
4	124	1	1	170 147 010		KABELBAUM		CABLE HARNESS	FAISCEAU DE CÂBLES	MAZO DE CABLES
4	125	1	1	170 143 030		MASSEBRÜCKE		GROUND CONNECTOR	PONT DE MASSE	PUENTE DE MASA
4	126	1	1	920 308 024		6KT-MUTTER	M8x1	HEXAGONAL NUT	ECROU HEXAGONAL	TUERCA HEXAGONAL
4	127	1	1	926 208 001		FEDERSCHEIBE	B8	SPRING WASHER	RONDELLE A RESSORT	ARANDELA ELASTICO
4	128	1	1	170 141 101		POLRAD KPL.		FLYWHEEL ASSY.	ROUE POLAIRE CPL.	VOLANTE ENCENDIDO
4	129	2	2	957 166 100		ANWERFKLINKE, SATZ		STARTER RATCHET CPL.	CLIQUET CPL.	TRINQUETE ARRANQUE CPL.
4	130	1	1	170 143 011		ZÜNDANKER		IGNITION COIL	INDUIT	FIJACIÓN DEL INDUCIDO
4	131	2	2	908 004 165		INNENSTERN-SCHRAUBE	4x16	SCREW	VIS	TORNILLO
4	132	1	1	170 140 100		SATZ POLRAD / ZÜNDANKER		SET FLYWHEEL / IGNITION COIL	JEU ROUE POLAIRE / INDUIT	JUEGO VOL. ENCENDIDO / FIJ. DEL INDUCIDO

DCS3410
DCS3410TH

5

Handgriffe
Handles
Poignées
Mangos

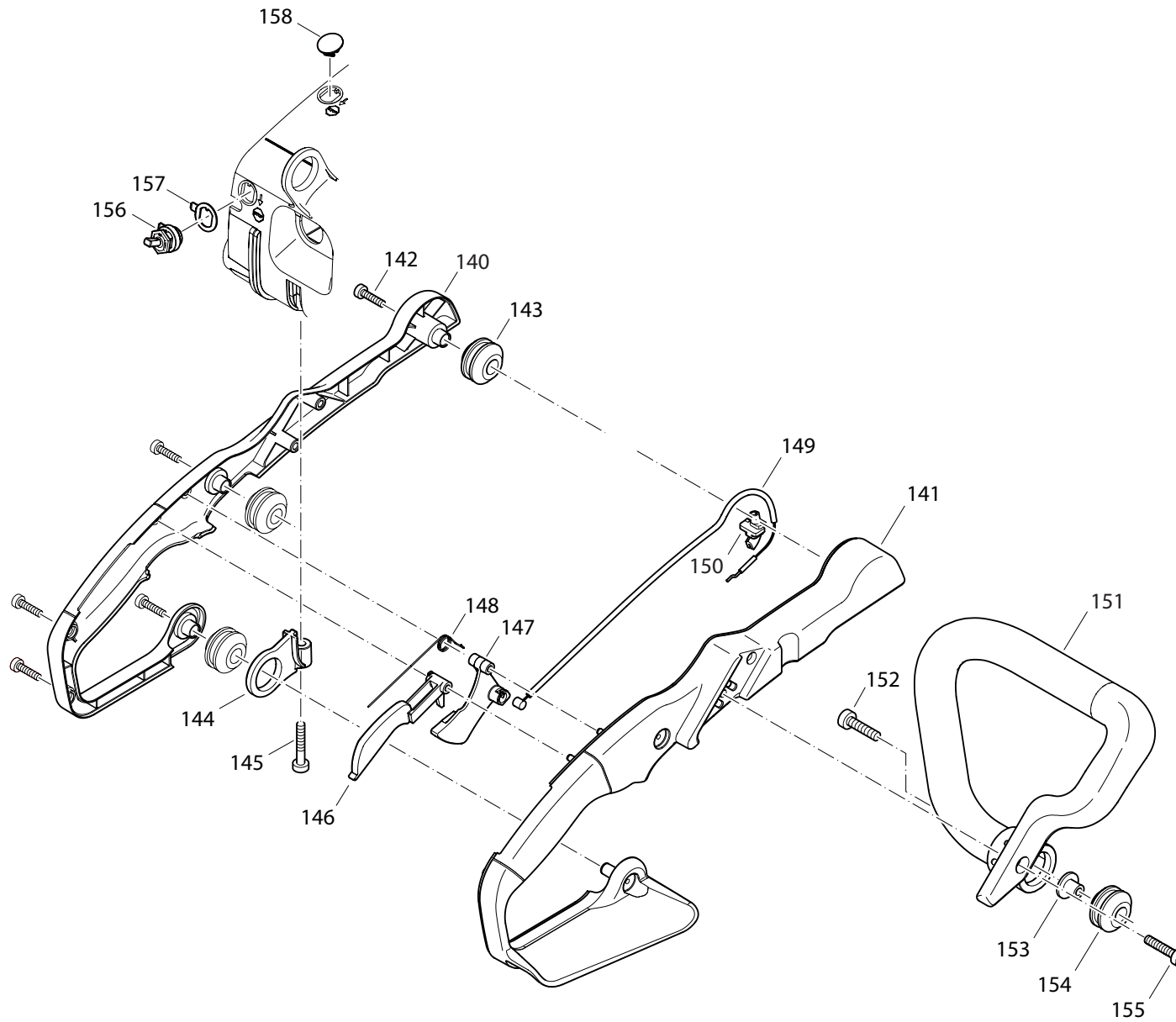

**DCS3410
DCS3410TH**



Seite / Page	Pos.	DCS3410 DCS3410TH	Teil-Nr. Part No. No. de pièce No. de pieza	Hinweise Notes Renseign. Nota	Bezeichnung	Spezifikation Specification	Description	Désignation	Denominación
5	140	1	172 311 010		GRIFFHÄLFTE LINKS		HANDLE HALF LEFT	DEMI-POIGNÉE GAUCHE	SEMI-MANGO IZQU.
5	141	1	172 313 010		GRIFFHÄLFTE RECHTS		HANDLE HALF RIGHT	DEMI-POIGNÉE DROIT	SEMI-MANGO DER.
5	142	5	913 340 204		INNENSTERN-SCHLITZ-SCHRAUBE	4x20	SCREW	VIS	TORNILLO
5	143	3	965 403 491		SCHWINGUNGSDÄMPFER		RUBBER BUFFER	AMORTISSEUR	AMORTIGUADOR
5	144	1	172 313 660		DÄMPFERHALTER BLAU		RUBBER BUFFER MOUNTING, BLUE	PORTE-SILENCIEUX BLEU	SOPORTE DE SILENCIOSO AZUL
5	145	1	913 650 304		INNENSTERN-SCHLITZ-SCHRAUBE	5x30	SCREW	VIS	TORNILLO
5	146	1	170 117 040		GASHEBELSPERRE		CATCH LEVER	LEVIER DE VERROUILLAGE	PALANCA TRINCADA
5	147	1	170 117 030		GASHEBEL		THROTTLE LEVER	LEVIER D' ACCÉLÉRATION	ACELERADOR
5	148	1	170 117 050		FEDER FÜR GASHEBEL		SPRING	RESSORT	MUELLE
5	149	1	172 312 010		GASBOWDENZUG		BOWDEN CABLE	CÂBLE DE COMMANDE	TRANSMIS. FLEXIBLE BOWDEN
5	150	1	170 312 020		UMLENKUNG		REDIRECTOR	DÉFLECTEUR	DESVIADOR
5	151	1	172 310 010		BÜGELGRIFF		TUBULAR HANDLE	POIGNÉE TUBULAIRE	MANGO TUBULAR
5	152	1	913 650 304		INNENSTERN-SCHLITZ-SCHRAUBE	5x30	SCREW	VIS	TORNILLO
5	153	1	036 114 020		BEFESTIGUNGSBUCHSE		FIXING BUSH	DOUILLE DE FIXATION	CASQUILLO DE AJUSTE
5	154	1	965 403 491		SCHWINGUNGSDÄMPFER		RUBBER BUFFER	AMORTISSEUR	AMORTIGUADOR
5	155	1	913 650 304		INNENSTERN-SCHLITZ-SCHRAUBE	5x30	SCREW	VIS	TORNILLO
5	156	1	170 146 020		KURZSCHLUßSCHALTER		SHORT-CIRCUIT SWITCH	INTERRUPTEUR COURT-CIRCUIT	INTERRUPTOR CORTO CIRCUITE
5	157	1	170 146 010		RINGFLACHSTECKER		FLAT RING CONNECTOR	CONNECTEUR PLAT CIRCULAIRE	CONECTOR PLANO REDONDO
5	158	1	170 111 060		STOPFEN KURZSCHLUßSCHALTER		PLUG	BOUCHON	TOPE DE CIERRE

TopHandle

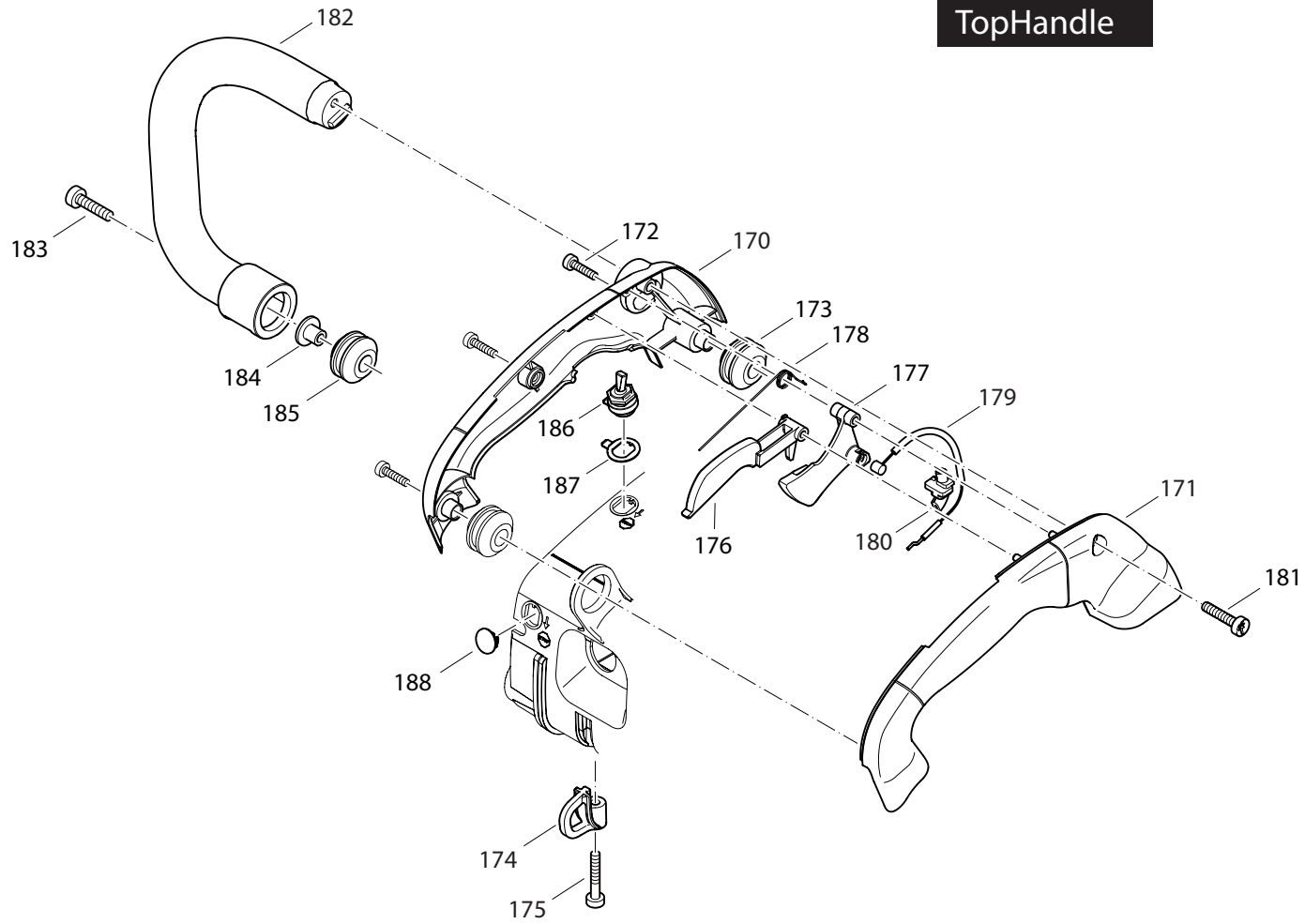

**DCS3410
DCS3410TH**



Seite / Page	Pos.	DCS3410	DCS3410TH	Teil-Nr. Part No. No. de pièce No. de pieza	Hinweise Notes Renseign. Nota	Bezeichnung	Spezifikation Specification	Description	Désignation	Denominación
6	170		1	170 311 010		GRIFFHÄLFTE LINKS	TH	HANDLE HALF LEFT	DEMI-POIGNÉE GAUCHE	SEMI-MANGO IZQU.
6	171		1	170 313 010		GRIFFHÄLFTE RECHTS	TH	HANDLE HALF RIGHT	DEMI-POIGNÉE DROIT	SEMI-MANGO DER.
6	172		3	913 340 204		INNENSTERN-SCHLITZ-SCHRAUBE	4x20	SCREW	VIS	TORNILLO
6	173		2	965 403 491		SCHWINGUNGSDÄMPFER		RUBBER BUFFER	AMORTISSEUR	AMORTIGUADOR
6	174		1	170 313 080		HALTERING	AI	EYE	BAGUE DE SUPPORT	ARO DE RETENCIÓN
6	175		1	913 650 304		INNENSTERN-SCHLITZ-SCHRAUBE	5x30	SCREW	VIS	TORNILLO
6	176		1	170 117 040		GASHEBELSPERRE		CATCH LEVER	LEVIER DE VERROUILLAGE	PALANCA TRINCADA
6	177		1	170 117 030		GASHEBEL		THROTTLE LEVER	LEVIER D' ACCÉLÉRATION	ACELERADOR
6	178		1	170 117 050		FEDER FÜR GASHEBEL		SPRING	RESSORT	MUELLE
6	179		1	170 312 010		GASBOWDENZUG	TH	BOWDEN CABLE	CÂBLE DE COMMANDE	TRANSMIS. FLEXIBLE BOWDEN
6	180		1	170 312 020		UMLENKUNG		REDIRECTOR	DÉFLECTEUR	DESVIADOR
6	181		1	913 650 304		INNENSTERN-SCHLITZ-SCHRAUBE	5x30	SCREW	VIS	TORNILLO
6	182		1	170 310 010		BÜGELGRIFF	TH	TUBULAR HANDLE	POIGNÉE TUBULAIRE	MANGO TUBULAR
6	183		1	913 650 304		INNENSTERN-SCHLITZ-SCHRAUBE	5x30	SCREW	VIS	TORNILLO
6	184		1	036 114 020		BEFESTIGUNGSBUCHSE		FIXING BUSH	DOUILLE DE FIXATION	CASQUILLO DE AJUSTE
6	185		1	965 403 491		SCHWINGUNGSDÄMPFER		RUBBER BUFFER	AMORTISSEUR	AMORTIGUADOR
6	186		1	170 146 020		KURZSCHLUßSCHALTER		SHORT-CIRCUIT SWITCH	INTERRUPTEUR COURT-CIRCUIT	INTERRUPTOR CORTO CIRCUITE
6	187		1	170 146 010		RINGFLACHSTECKER		FLAT RING CONNECTOR	CONNECTEUR PLAT CIRCULAIRE	CONECTOR PLANO REDONDO
6	188		1	170 111 060		STOPFEN KURZSCHLUßSCHALTER		PLUG	BOUCHON	TOPE DE CIERRE

DCS3410
DCS3410TH

7

Kettenradschutz, Kettenspanner
Sprocket guard, chain tensioner
Protège-pignon, tendeur de chaîne
Protector de piñon, tensor de la cadena

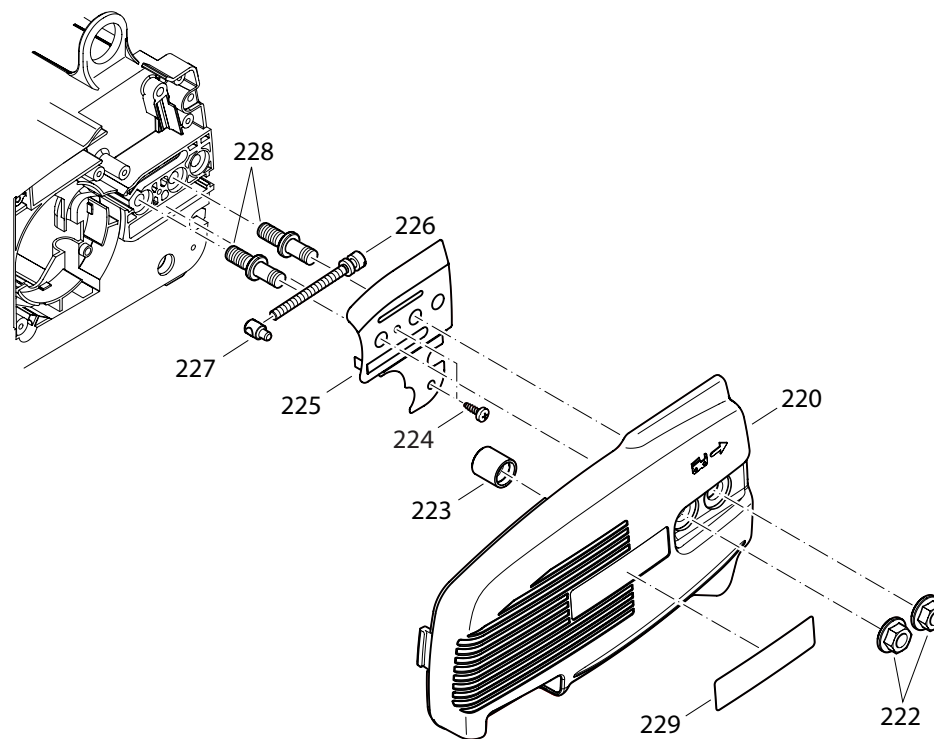

DCS3410
DCS3410TH



Seite / Page	Pos.	DCS3410	DCS3410TH	Teil-Nr. Part No. No. de pièce No. de pieza	Hinweise Notes Renseign. Nota	Bezeichnung	Spezifikation Specification	Description	Désignation	Denominación
7	220	1	1	170 213 600		KETTENRADSCHUTZ BLAU		SPROCKET GUARD, BLUE	PROTÈGE-PIGNON BLEU	PROTECTOR DE PIÑON AZUL
7	222	2	2	923 208 004		6KT-MUTTER MIT BUND	M8	HEXAGONAL NUT	ECROU HEXAGONAL	TUERCA HEXAGONAL
7	223	1	1	170 213 100		KETTENFANGROLLE		CHAIN CATCH	ARRÊTE-CHAÎNE	BULÓN DE RETENCIÓN
7	224	2	2	915 735 100		KREUZSCHLITZ-KUNSTSTOFFSCHRAUBE	3,5x10	SCREW	VIS	TORNILLO
7	225	1	1	170 111 070		KETTENFÜHRUNGSBLECH		GUIDE PLATE	TÔLE DE GUIDAGE	CHAPA DE GUÍA
7	226	1	1	036 213 090		SPANNSCHRAUBE		TENSIONING SCREW	VIS DE TENSION	TORNILLO DE TENSIÓN
7	227	1	1	001 213 042		MUTTER MIT ZAPFEN		NUT WITH PIVOT	ECROU AVEC PIVOT	TUERCA CON ESPIGA
7	228	2	2	036 110 021		SCHIENENBOLZEN, GELB		BOLT, YELLOW	BOULON, JAUNE	BULÓN, AMARILLO
7	229	1	1	980 114 912		AUFKLEBER KETTENRADSCHUTZ	MAKITA	LABEL	PLAQUE	CALCOMANIA

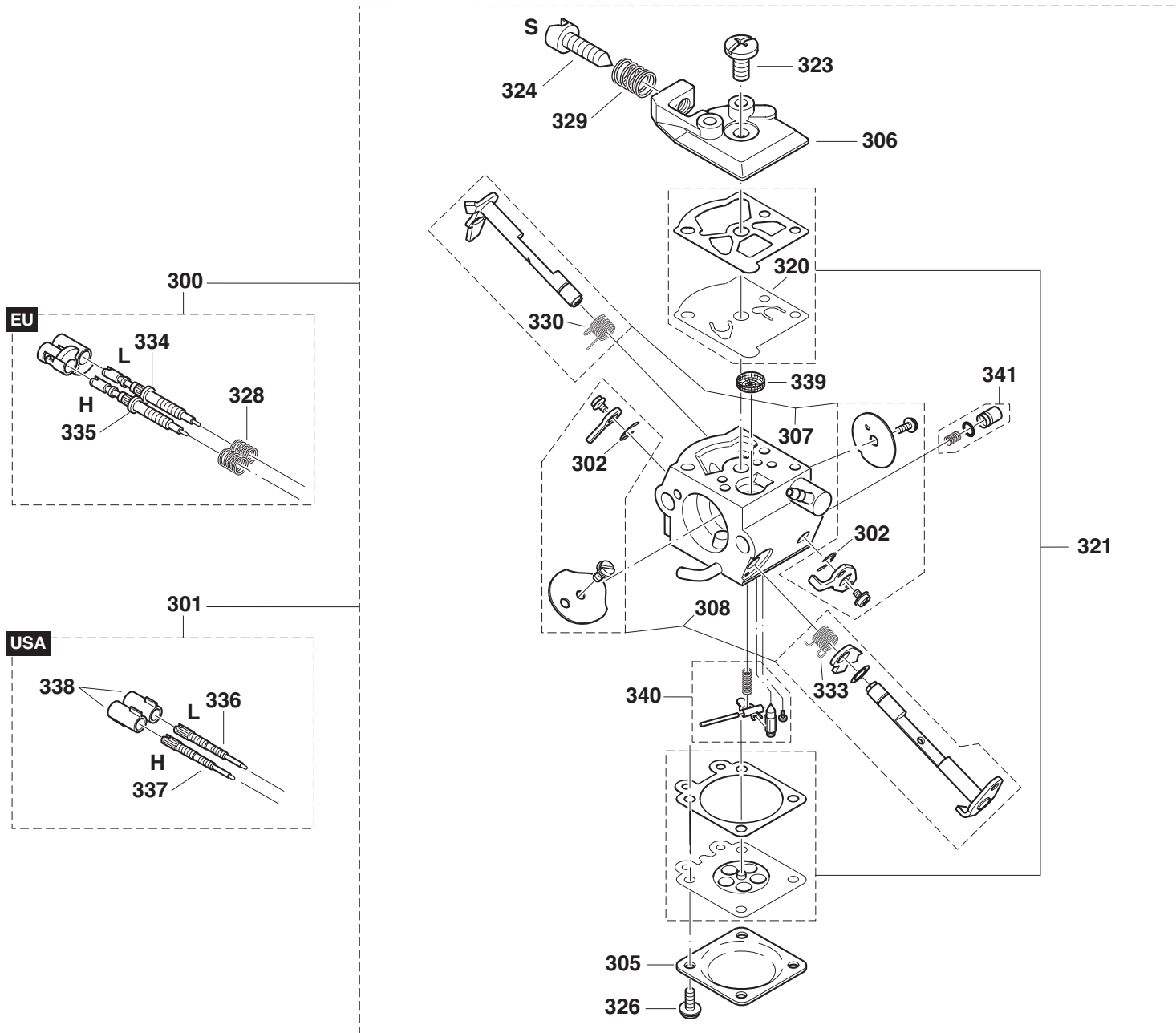

**DCS3410
DCS3410TH**



Seite / Page	Pos.	DCS3410	DCS3410TH	Teil-Nr. Part No. No. de pièce No. de pieza	Hinweise Notes Renseign. Nota	Bezeichnung	Spezifikation Specification	Description	Désignation	Denominación
8	300	1	1	170 151 100		VERGASER KPL.	LC-EU	CARBURETOR CPL.	CARBURATEUR CPL.	CARBURADOR CPL.
8	301	1	1	170 151 200		VERGASER KPL.	USA	CARBURETOR CPL.	CARBURATEUR CPL.	CARBURADOR CPL.
8	302	2	2	119 151 350		SICHERUNGSSCHEIBE		SAFETY WASHER	RONDELLE SÉCURITÉ	ARANDELA SEGURIDAD
8	305	1	1	021 151 120		MEMBRANDECKEL		DIAPHRAGM COVER	COUVERCLE DE MEMBRANE	TAPA DE MEMBRANA
8	306	1	1	021 151 160		PUMPENDECKEL KPL.		PUMP COVER	COUVERCLE DE POMPE	TAPA DE BOMBA
8	307	1	1	957 151 060		REP.-SATZ DROSSELWELLE		KIT THROTTLE SHAFT	JEU AXE CLAPET D'ÉTRANG.	JUEGO EJE VÁLVULA REG.
8	308	1	1	957 151 040		REP.-SATZ CHOKEWELLE		KIT CHOKE SHAFT	JEU AXE CLAPET D'AIR	JUEGO EJE VÁLVULA AIRE
8	320	1	1	021 151 150		PUMPENMEMBRANE GUMMI		PUMP DIAPHRAGM, RUBBER	MEMBRANE DE POMPE, CAOUTCH.	MEMBRANA DE LA BOMBA, CAUCHO
8	321	1	1	021 151 540		SATZ MEMBRANE UND DICHTUNGEN		SET DIAPHRAGM / GASKETS	JEU DE MEMBRANES / JOINTS	JUEGO MEMBRANAS / JUNTAS
8	323	1	1	118 151 190		SCHRAUBE		SCREW	VIS	TORNILLO
8	324	1	1	378 151 210		LEERLAUFANSCHLAGSCHRAUBE	S	IDLE SPEED SCREW	VIS DE BUTÉE DE RALENTI	TORNILLO DE TOPE
8	326	4	4	378 151 220		SCHRAUBE		SCREW	VIS	TORNILLO
8	328	2	2	021 151 530		FEDER		SPRING	RESSORT	RESORTE
8	329	1	1	170 151 260		FEDER		SPRING	RESSORT	RESORTE
8	330	1	1	001 151 310		DREHFEDER		SPRING	RESSORT	RESORTE
8	333	1	1	170 151 280		DREHFEDER		SPRING	RESSORT	RESORTE
8	334	1	1	001 151 810		LEERLAUF-STELLSCHRAUBE	L - EU	IDLE ADJUSTMENT SCREW	VIS DE RÉGL. DE RALENTI	TORNILLO REGULADOR
8	335	1	1	001 151 820		VOLLGAS-STELLSCHRAUBE	H - EU	MAIN ADJUSTMENT SCREW	VIS DE RÉGL. PLEIN GAZ	TORNILLO REGULADOR
8	336	1	1	170 151 350		LEERLAUF-STELLSCHRAUBE	L - USA	IDLE ADJUSTMENT SCREW	VIS DE RÉGL. DE RALENTI	TORNILLO REGULADOR
8	337	1	1	170 151 360		VOLLGAS-STELLSCHRAUBE	H - USA	MAIN ADJUSTMENT SCREW	VIS DE RÉGL. PLEIN GAZ	TORNILLO REGULADOR
8	338	1	1	170 151 330		LIMITER CAP	USA	LIMITER CAP	CAPUCHON LIMITEUR	CAPUCHONE LIMITADORE
8	339	1	1	021 151 180		SIEB		SCREEN	FILTRE	TAMIZ
8	340	1	1	957 150 040		SATZ STEUERTEILE		SET OF CONTROL PARTS	JEU DE PIÈCES DE COMMANDE	JUEGO PIEZAS DE MANDO
8	341	1	1	957 151 070		BESCHLEUNIGUNGSPUMPE KPL.		ACCELERATOR	POMPE DE REPRISE	BOMBA DE ACELERACIÓN

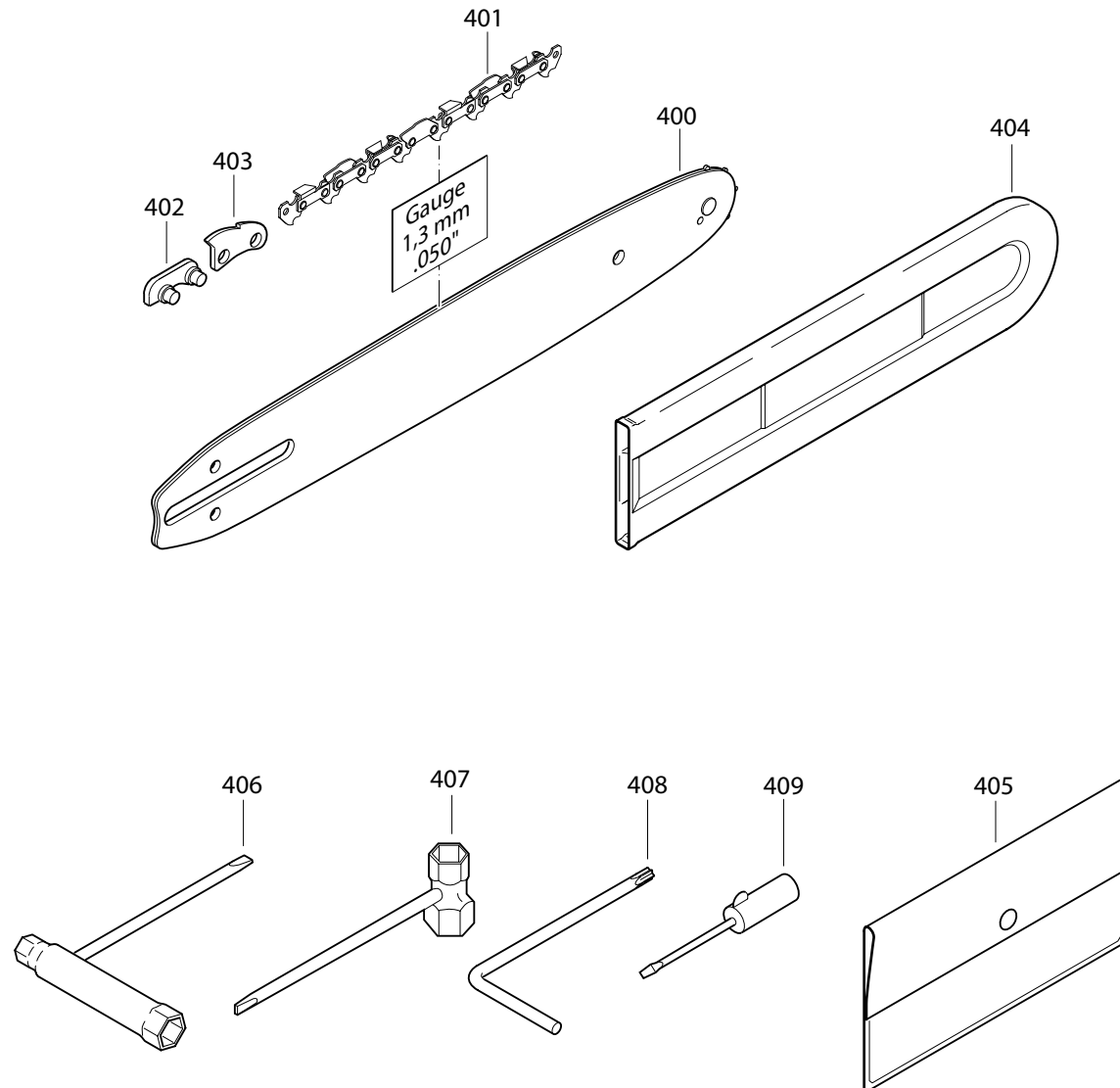

**DCS3410
DCS3410TH**



Seite / Page	Pos.	DCS3410	DCS3410TH	Teil-Nr. Part No. No. de pièce No. de pieza	Hinweise Notes Renseign. Nota	Bezeichnung	Spezifikation Specification	Description	Désignation	Denominación
9	400		1	442 025 661		STERNSCHIENE MAKITA	3/8" .050" 25CM-10"	SPROCKET NOSE BAR	GUIDE À ÉTOILE	GUÍA CON ESTRELLA
9	400	1	1	442 030 661		STERNSCHIENE MAKITA	3/8" .050" 30CM-12"	SPROCKET NOSE BAR	GUIDE À ÉTOILE	GUÍA CON ESTRELLA
9	400	1	1	442 035 661		STERNSCHIENE MAKITA	3/8" .050" 35CM-14"	SPROCKET NOSE BAR	GUIDE À ÉTOILE	GUÍA CON ESTRELLA
9	401		1	528 092 640		SÄGEKETTE	3/8" .050" 25CM-10"	SAW CHAIN	CHAÎNE	CADENA
9	401	1	1	528 092 646		SÄGEKETTE	3/8" .050" 30CM-12"	SAW CHAIN	CHAÎNE	CADENA
9	401	1	1	528 092 652		SÄGEKETTE	3/8" .050" 35CM-14"	SAW CHAIN	CHAÎNE	CADENA
9	402	1	1	558 092 010		AUSSENLASCHE MIT NIET	3/8" .050"	TIE STRAP WITH RIVETS	ECLISSE EXTERIEURE AVEC RIVETS	TIRA EXTER. CON REMACHE
9	403	1	1	558 092 000		SICHERHEITSLASCHE	3/8" .050"	SAFETY TIE STRAP	ECLISSE DE SÉCURITE	TIRA SEGURIDAD
9	404	1	1	952 100 633		KETTENSCHUTZ MAKITA SCHWARZ		CHAIN PROTECTION	PROTECTION CHAÎNE	PROTECTOR DE CADENA
9	405	1		950 004 002		WERKZEUGTASCHE, GROSS		PLASTIC BAG	POCHETTE EN PLASTIQUE	CARTERA HERRAMIENTAS
9	405		1	950 004 001		WERKZEUGTASCHE		PLASTIC BAG	POCHETTE EN PLASTIQUE	CARTERA HERRAMIENTAS
9	406	1		941 719 140		KOMBISCHLÜSSEL	19/13	UNIVERSAL WRENCH	CLÉ COMBINÉE	LLAVE DE BUJÍA
9	407		1	941 719 131		KOMBISCHLÜSSEL	19/13	UNIVERSAL WRENCH	CLÉ COMBINÉE	LLAVE DE BUJÍA
9	408	1	1	940 827 000		WINKELSCHRAUBENDREHER	T27	ANGLED SCREW DRIVER	CLÉ ANGLE	LLAVE ANGULAR
9	409	1	1	944 340 001		SCHRAUBENDREHER		SCREW DRIVER	TOURNEVIS	DESTORNILLADOR

1	Tank, Kettenbremse	Tank, chain brake	Réservoir, frein de chaîne	Depósito, freno de cadena
2	Zylinder, Luftfilter, Schalldämpfer	Cylinder, air filter, muffler	Cylindre, filtre à air, pot d' échappement	Cilíndro, filtro de aire, silencioso
3	Ölpumpe, Kupplung	Oil pump, clutch	Pompe à huile, embrayage	Bomba de aceite, embrague
4	Zünderlektronik, Anwerfvorrichtung	Ignition electronics, starter	Allumage électronique, dispos. de démarrage	Bobina encendido, dispos. de arranque
5	Handgriffe	Handles	Poignées	Mangos
6	Handgriffe - TopHandle	Handles - TopHandle	Poignées - TopHandle	Mangos - TopHandle
7	Kettenradschutz, Kettenspanner	Sprocket guard, chain tensioner	Protège-pignon, tendeur de chaîne	Protector de piñon, tensor de la cadena
8	Vergaser	Carburetor	Carburateur	Carburador
9	Sägeschienen, Sägeketten, Werkzeug	Guide bars, saw chains, tools	Guide-chaîne et chaînes, outils	Rieles guía, cadenas sierra, herramientas

	Zeichenerklärung	Key to symbols	Légende	Explicación de símbolos
1999999 2000000 2003.04 TI 2003/07 Acc. = { m Corr.	Produktion bis Serien-Nr. Neues Teil ab Serien-Nr. Neues Teil ab Jahr / Monat Siehe Technische Information Jahr / Nr. Zubehör (nicht im Lieferumfang) Keine Serienausführung, jedoch verwendbar Beinhaltet Positions-Nr. Meterware Druckfehlerberichtigung	Production to serial number New part from serial number New part from Year / Month See Technical Information Year / No. Accessories (not included in the delivery inventory) No standard execution, may be used Contains item number Sold by the meter Error correction	Production jusqu'à n° de série Nouvelle pièce à partir du n° de série Nouvelle pièce à partir de année / mois Voir information technique année / n° Accessoires (non compris dans la livraison) Aucune exécut. en série, cependant utilisable contient n° de numéro Au mètre Rectification d' erreurs	Producción hasta N° de serie Pieza nueva a partir de N° de serie Pieza nueva a partir de año / mes Véase inform. técnico año / N° Accesorios (no incluido en la extensión del suministro) No es de serie, pero sirve Contiene pos N° Por metro Fe de erratas
	Änderungen vorbehalten	Specifications subject to change without notice	Changements sans préavis	Mejoras constructivas sin previo aviso