



A world's leading manufacturer of power tools

Double Insulation

Electronic Speed Control

Super Joint System

Soft Start

Dust Collecting

Carrying Case

Wall Chaser

125 mm (5") Model SG1250

*Clean, Compact and Comfortable!!
Now Makita releases the New Wall Chaser!*



NEW



A world's leading manufacturer of power tools

Makita Wall Chaser offers the most

Performance Data

Working Speed

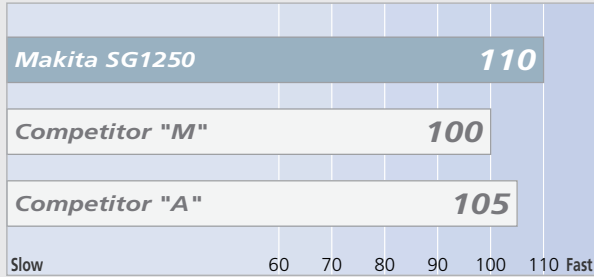

Dust Collecting

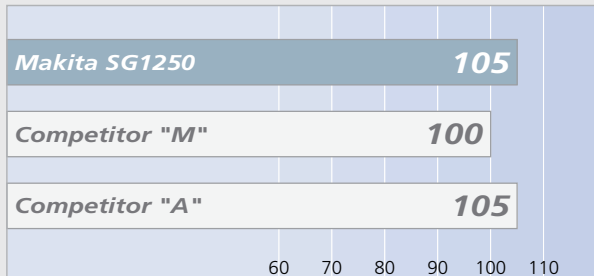

- Numbers in chart below are relative values when setting "M's" capacity as 100.
- It may differ under some conditions.

Cutting width

Adjustable cutting width in 9 stage by inserting spacers of 3 mm (1/8") and 6 mm (1/4") in thickness.

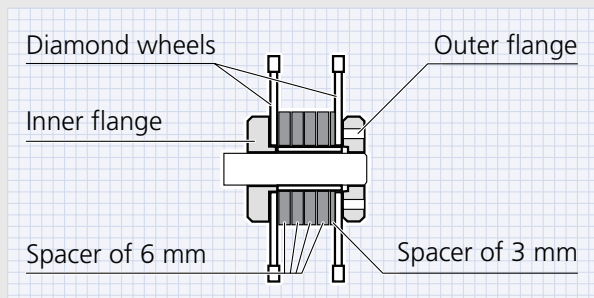

Cutting width	Q'ty of 6 mm spacer	Q'ty of 3 mm spacer
6 mm		1 pc.
9 mm	1 pc.	
12 mm	1 pc.	1 pc.
15 mm	2 pcs.	
18 mm	2 pcs.	1 pc.
21 mm	3 pcs.	
24 mm	3 pcs.	1 pc.
27 mm	4 pcs.	
30 mm	4 pcs.	1 pc.

1. Ergonomic handle



Comfortable gripping by ergonomically designed handle.

2. Dust collector



Connectable with dust collector. Clean work.

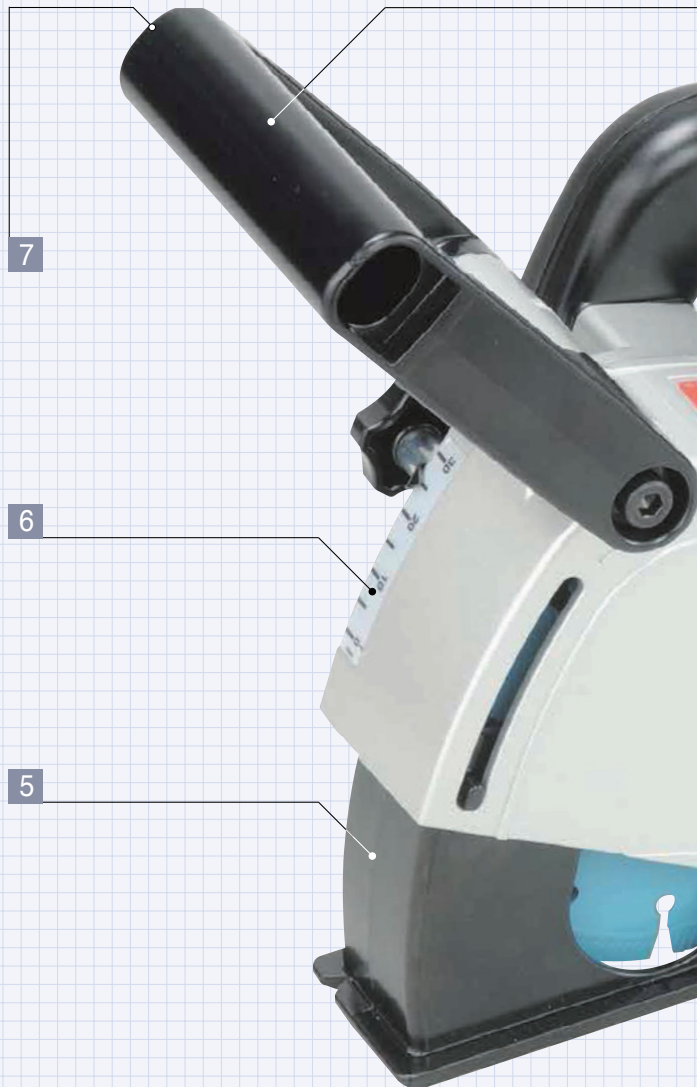

SJS (Super Joint System) Provides the following benefits.

- Smooth and comfortable cutting work.
- Suppression of the shock of accidental wheel lock.
- Protection of the mechanical section from the shock of accidental wheel lock.

efficient cutting of clean edged grooves for channels.

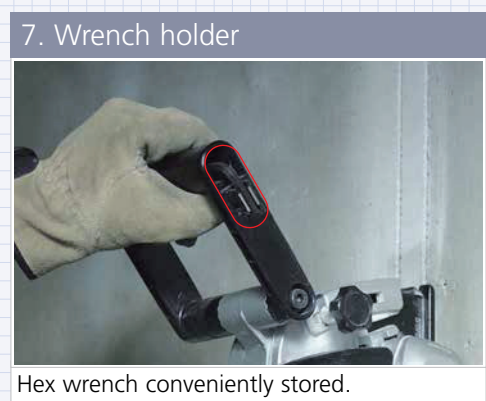
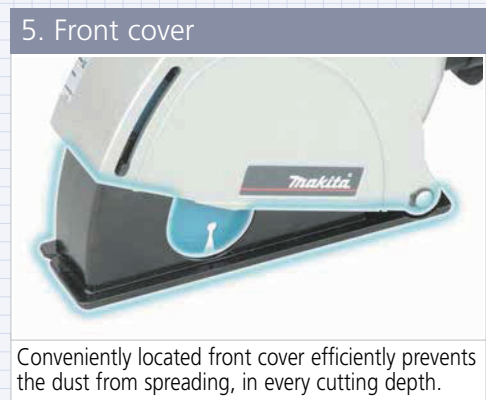
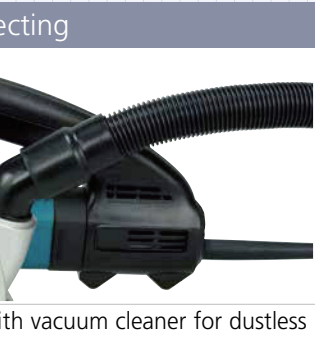

SG1250 Wall chaser 125 mm (5")

- ### Electronic features
- Soft start for suppressing shock at start-ups
 - Auto shut-off when overloaded
 - Speed control

Specifications

Wall chaser

Blade diameter	125 mm (5")
Cutting depth	0 - 30 mm
Possible adjustment of Cutting width	6 - 30 mm
Continuous rating Input	1,400 W
No load speed	9,000 min ⁻¹ (rpm)
Overall length	346 mm (13-5/8")
Net weight	3.9 kg (8.6 lbs)

Specifications may differ from country to country.

Dimension

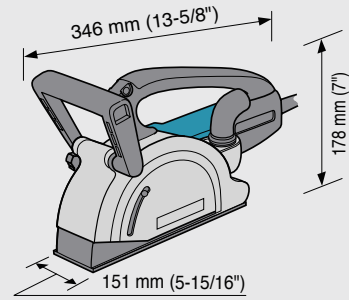

Standard equipment

Wall chaser

	Part No.		Part No.
Diamond wheel (2 pcs.)	A-80438	Lock nut wrench	782407-9
Hex wrench	783204-6	Plastic carrying case	824709-8

Note: The standard equipments may differ from country to country.

Optional Accessories

Wall chaser

Wheel Style		D	T	X	H	d	Color	Part No.	For Material
Shape	Dry or Wet								
Segmented	Dry	125	2	7.5	22.23	-	Blue	A-80438*	Concrete
Segmented wave		125	2	7.5	22.23	-	Gold	B-02054	Concrete, Hard Concrete, Granite

* Standard equipment