

DEWALT

NEW

**TSTAK™ STACKABLE
STORAGE SYSTEM**

Stanley Black & Decker Ltd

210 Bath Road

Slough

Berkshire

SL1 3YD

Customer Services

Tel: 0114 291 7264

www.DEWALT.eu

www.DEWALT.eu

GUARANTEED TOUGH.™



TSTAK™ INTERLOCKING STACKABLE STORAGE

NEW

THE NEW TSTAK™ RANGE FROM DEWALT IS THE PERFECT PARTNER FOR TRADE PROFESSIONALS.

With its **strong** easy to use interlocking system, units can be configured to your exact requirements, giving the ultimate flexible storage solution.

Manufactured and tested to the highest standards to ensure long life and durability, TSTAK™ keeps everything you need for the job organised exactly how you want them.



- STATIC
LOAD TEST
- DROP &
IMPACT TEST
- HINGE
DURABILITY TEST
- LATCH
DURABILITY TEST
- HANDLE
DURABILITY TEST

RANGE FEATURES



Large, comfortable bi-material handles for extra grip



Tool case foam can be configured to fit *your* tools for ultimate protection



Rugged and hardwearing metal latches improve durability



All models include label windows for improved organisation



Connecting units is quick and easy with the simple interlocking system



Built with metal draw rails for smooth operation



TSTAK I & II tool cases keep your tools safe & secure



Units include adjustable drawer organiser and storage tubs





TSTAK™ I

DWST1-70704 440mm x 185.1mm x 331.7mm

- **14L** Powertool storage top unit with heavy duty handles.
- Includes organiser in the lid for small parts (drill bits, screws, plugs).
- Fitted with padlock eyes to keep tools safe and secure.
- Complete with adaptable foam insert to keep powertools protected against shock.

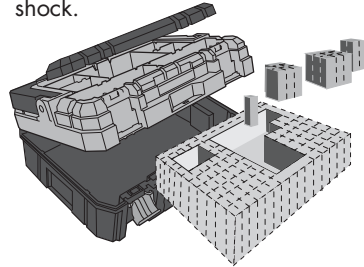

TSTAK™ III

DWST1-70705 440mm x 176mm x 314.2mm

- **9.5L** Deep drawer storage unit comes with 2 large and 4 small removable storage totes
- Built with metal drawer runners for smooth and reliable operation

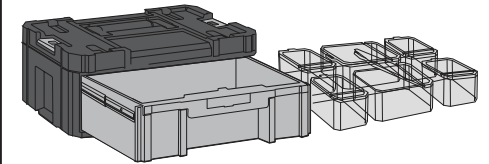

TSTAK™ II

DWST1-70703 440mm x 176mm x 331.7mm

- **13.5L** Powertool storage top unit
- Complete with adaptable foam insert to keep powertools protected against shock.
- Fitted with padlock eyes to keep tools safe and secure.
- Also available as **TSTAK™ COMBO**.

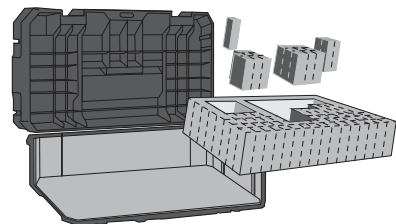

TSTAK™ IV

DWST1-70706 440mm x 176mm x 314.2mm

- **8L capacity** 2 shallow drawers for organising and storing small parts.
- Draw dividers can be removed and reconfigured for maximum flexibility.
- Also available as **TSTAK™ COMBO**.

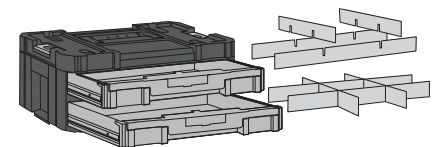
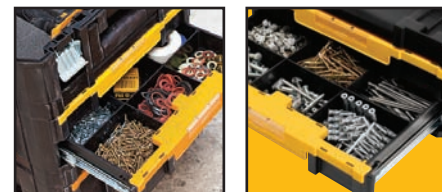

TSTAK™ COMBO

DWST1-70702

21.5L 440mm x 326.1mm x 331.7mm

TSTAK™ II



TSTAK™ IV



- With **21.5L** capacity, **TSTAK™ COMBO** is the ideal compact storage solution for trade professionals.
- Powertool storage top unit comes complete with adaptable foam insert to keep powertools protected against shock.
- Includes 2 shallow drawers for organising and storing small parts.
- Draw dividers can be removed and reconfigured for maximum flexibility.

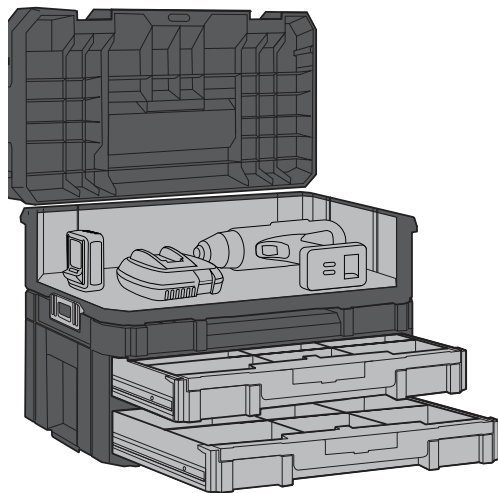

BUILD THE SYSTEM TO SUIT YOUR NEEDS

MAKE TSTAK™ YOUR OWN. THE QUICK INTERCONNECTING SYSTEM LET'S YOU RECONFIGURE YOUR TOOLBOX AS YOU NEED IT.

MODELS AVAILABLE

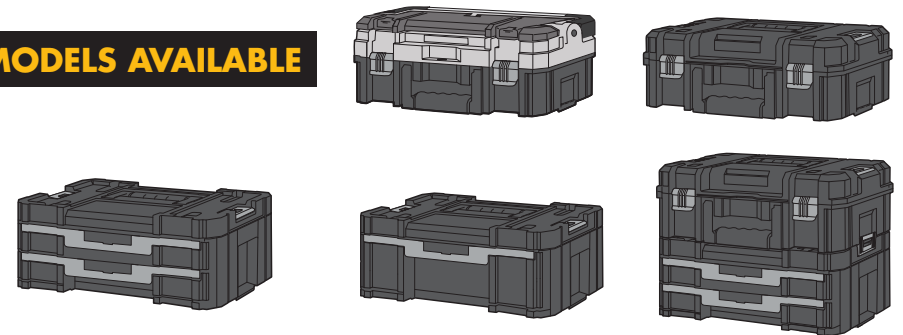

USE THE BEST CONFIGURATION FOR YOU

