

GB

If you have questions or comments, contact us.

www.dewalt.eu

DEWALT®

INSTRUCTION MANUAL

DW0811 Self-Leveling 360° Line/Cross Line Laser Pointer

(Feb. 14) Part No.79002844 Copyright © 2014 DEWALT

IF YOU HAVE ANY QUESTIONS OR COMMENTS ABOUT THIS OR ANY DEWALT TOOL, CALL US AT: TEL: 01753-56 70 55 FAX: 01753-57 21 12 OR VISIT OUR WEBSITE: WWW.DEWALT.EU.

Safety



WARNING: To reduce the risk of injury, read the safety manual provided with your product or access it online at www.DeWALT.eu

Use of controls or adjustments or performance of procedures other than those specified herein may result in hazardous radiation exposure

WARNING LABELS

For your convenience and safety, the following label is on your laser.

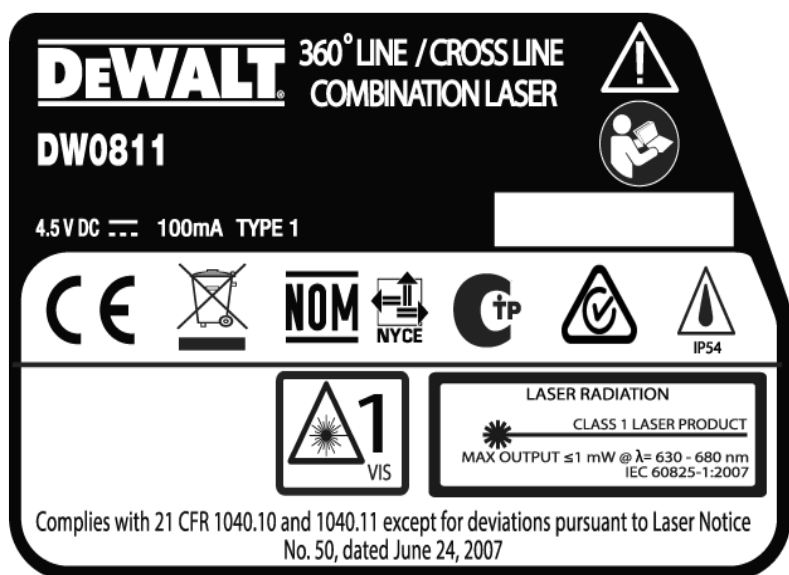

⚠ CAUTION: LASER RADIATION - DO NOT STARE INTO BEAM. CLASS 1 LASER PRODUCT.

Laser Information

The DW0811 laser level is a class 1 laser product and complies with 21 CFR 1040.10 and 1040.11 except for deviations pursuant to laser notice No. 50, dated June 24, 2007.

Product Overview

The DW0811 laser level is a self-leveling laser tool that can be used for horizontal (level) and vertical (plumb) alignment and square alignment. This tool comes fully assembled and has been designed with features that allow for quick and easy set-up. Please read and understand all instructions within this instruction manual in addition to the Safety Manual prior to use.

Specifications

SPECIFICATIONS	
Light Source	Semiconductor laser diode
Laser Wavelength	630-680 nm visible
Laser Power	<1.0 mW (each beam) CLASS 1 LASER PRODUCT
Working Range	30m (100') 50m (165') with detector
Accuracy* (Vertical)	± 5/32" @ 30' (±4 mm @ 10 m)
Accuracy* (Level)	± 5/32" @ 30' (±4 mm @ 10 m)
Indicators	Flashing Indicator: battery low Flashing Laser: tilt range exceeded
Power Source	3 AA size batteries (4.5V DC)
Operating Temperature	20 °F to 120 °F (-10 °C to 50 °C)
Storage Temperature	-5 °F to 140 °F (-20 °C to 60 °C)
Environmental	IP54

Keypad, Modes and LED.

Power switch.

The Power ON/OFF switch is located on the rear of the tool as shown in figure 1. When the switch (C) is in the OFF/LOCKED position, the unit will remain off and the pendulum will be locked. When the on/off switch (C) is in the ON/UNLOCKED position, the unit will be powered ON and the pendulum will be released from the locked position and self level.

Keypad.

The keypad located on the top of the tool provides activation keys for selection of laser dots and / or line function.

Low Battery Indicator.

The DW0811 is equipped with a low battery indicator on the keypad as shown in Figure 2. The indicator light is located on the keypad. When the light flashes, the batteries are low and need to be replaced. The laser may continue to operate for a short time while the batteries continue to drain. After fresh batteries are installed and the laser is turned on again, the indicator light will remain green.

Out of Tilt Range Indicator

The DW0811 is equipped with an out of tilt indicator on the keypad as shown in Figure 2. When the tilt range (> 4° tilt) has been exceeded the LED will turn on and the laser beam will flash. The flashing beam indicates the tilt range has been exceeded and the tool IS NOT LEVEL (OR PLUMB) AND SHOULD NOT BE USED FOR DETERMINING OR MARKING LEVEL (OR PLUMB). Try repositioning the laser on a more level surface.

Batteries & Power

Your laser tool requires 3 x AA batteries. (E)

Use only new, high-quality batteries for best results.

- Ensure batteries are in good working condition. If the low battery indicator light is flashing, the batteries need replacement.
- To extend battery life, turn laser off when not working with or marking the beam.

Set Up

LEVELING THE LASER

This tool is self-leveling. It is calibrated at the factory to find plumb as long as it is positioned on flat surface within 4° of level. As long as the tool is properly calibrated, no manual adjustments must be made.

To ensure the accuracy of your work, check to make sure your laser is calibrated often. See **Field Calibration Check**.

- Before attempting to use the laser, make sure it is positioned securely, on a smooth, flat surface.
- Always mark the center of the dot or pattern created by the laser.
- Extreme temperature changes may cause movement of internal parts that can affect accuracy. Check your accuracy often while working. See **Field Calibration Check**.
- If the laser has been dropped, check to make sure your laser is calibrated. See **Field Calibration Check**.

OPERATION

Turning the Laser On and Off (Fig. 6)

- With the laser off, place it on a stable, flat surface. Turn the laser on by sliding the on/off switch (A) to the ON/UNLOCKED position.
- Activate or deactivate the desired function using the keypad (B) located on the side of the tool. It can project 360° horizontal line (C) and a vertical line (D)
- To turn the laser off, slide the the on/off switch (A) to the locked position.

The DW0811 is equipped with a locking pendulum mechanism. This feature is only activated when the laser is switched off.

Using the Laser

The beams are level or plumb as long as the calibration has been checked (see **Field Calibration Check**) and the laser beam is not flashing (see **Out of Tilt Range Indicator**).

The tool can be used to transfer points using any combination of the five beams and/or horizontal line.

USING THE LASER WITH ACCESSORIES

The laser is equipped with both 1/4" x 20 and 5/8" x 11 female threads on the bottom of the unit. These threads may be used to accommodate current or future DEWALT accessories. Only use DEWALT accessories specified for use with this product. Follow the directions included with the accessory.

⚠ WARNING: Since accessories, other than those offered by DEWALT, have not been tested with this product, use of such accessories with this tool could be hazardous. To reduce the risk of injury, only DEWALT recommended accessories should be used with this product.

Recommended accessories for use with your tool are available at extra cost from your local dealer or authorized service center. If you need assistance in locating any accessory, please contact DEWALT Industrial Tool Co., Visit our website: www.DeWALT.eu.

Field Calibration Check

Levelling Accuracy

(See Figure 1)

Calibration check should be performed using a distance no shorter than the distance of the applications for which the tool will be used.

- Place the laser tool on a tripod and close to wall #1 as shown in Fig 1. Turn on both a horizontal and vertical line. Mark the intersection of the points P_1 .
 - Rotate laser tool 180° and mark point P_2 at intersection of the lines on wall #2
 - Move laser tool close to wall #2 and align point P_3 at previously marked point P_2
 - Rotate laser tool 180° and mark point P_4 on wall #1
 - Measure the vertical distance between P_1 and P_4 to get D_3 .
- If the measurement is greater than the values shown below, the laser must be serviced at an authorized service center

Distance Between Walls	Measurement Between Marks (D_3)
10' (3 m)	1/8" (3 mm)
20' (6 m)	7/32" (5.5 mm)
30' (10 m)	5/16" (8 mm)

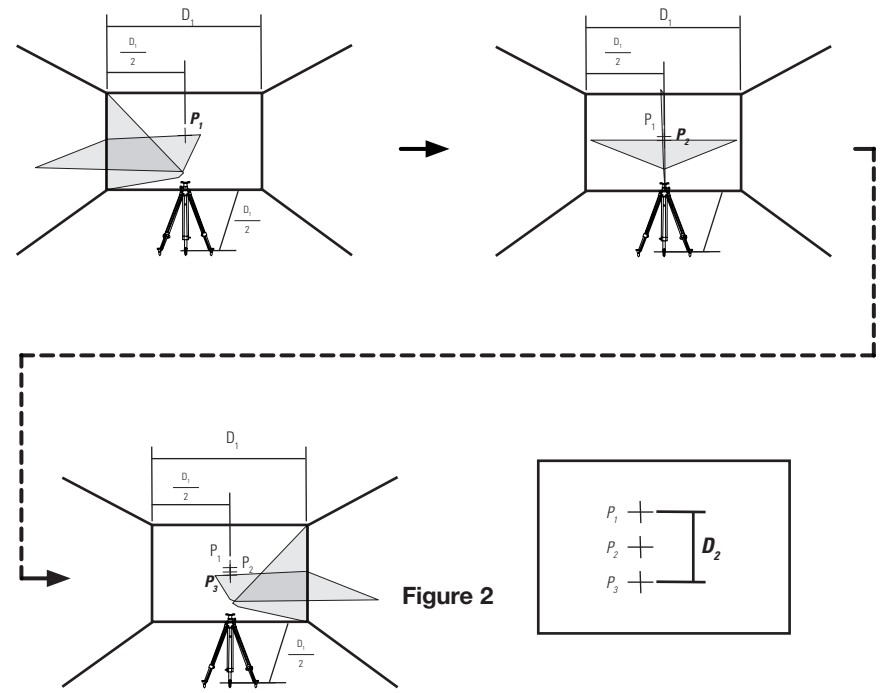

Horizontal Beam Accuracy

(See Figure 2)

- Place laser tool as shown with laser ON. Aim vertical beam towards the first corner or a set reference point. Measure out half of the distance D_1 and mark point P_1 .
 - Rotate laser tool and align front vertical laser beam with point P_1 . Mark point P_2 where the horizontal and vertical laser beams cross.
 - Rotate laser tool and aim vertical beam towards the second corner or set reference point. Mark point P_3 so that it is vertically in line with points P_1 and P_2 .
 - Measure the vertical distance D_2 between the highest and lowest point.
- If the measurement is greater than the values shown below, the laser must be serviced at an authorized service center.

Distance Between Walls	Measurement Between Marks (D_3)
10' (3 m)	1/8" (3 mm)
20' (6 m)	7/32" (5.5 mm)
30' (10 m)	5/16" (8 mm)

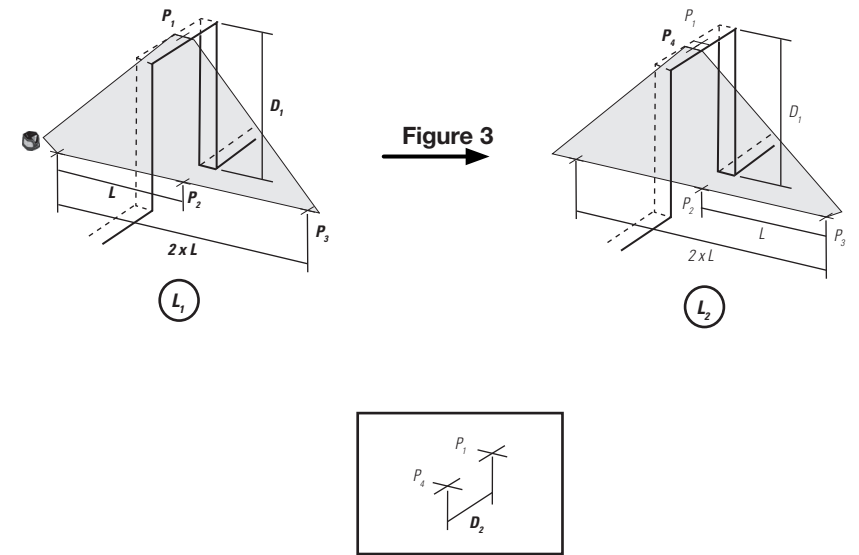

Vertical Beam Accuracy

(See Figure 3)

- Measure the height of a reference point to get distance D_1 . Place laser tool as shown with laser ON. Aim vertical beam towards reference point. Mark points P_1 , P_2 , and P_3 as shown.
 - Move laser tool to opposite side of reference point and align the same vertical beam with P_2 and P_3 .
 - Measure the horizontal distances between P_1 and the vertical beam from the 2nd location.
- If the measurement is greater than the values shown below, the laser must be serviced at an authorized service center.

Distance Between Walls	Measurement Between Marks (D_3)
10' (3 m)	1/8" (3 mm)
20' (6 m)	7/32" (5.5 mm)
30' (10 m)	5/16" (8 mm)

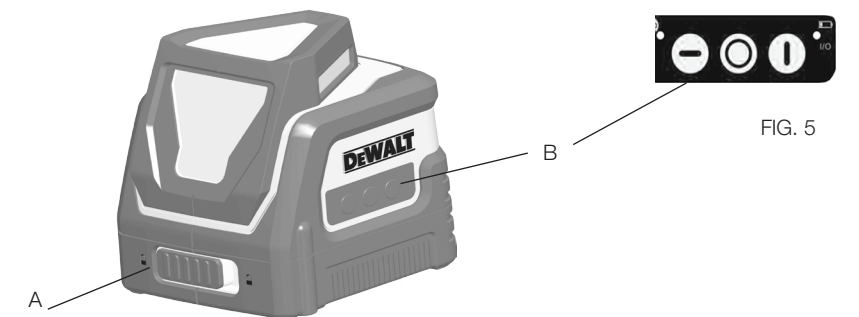
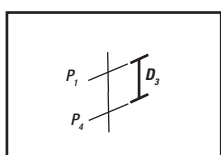
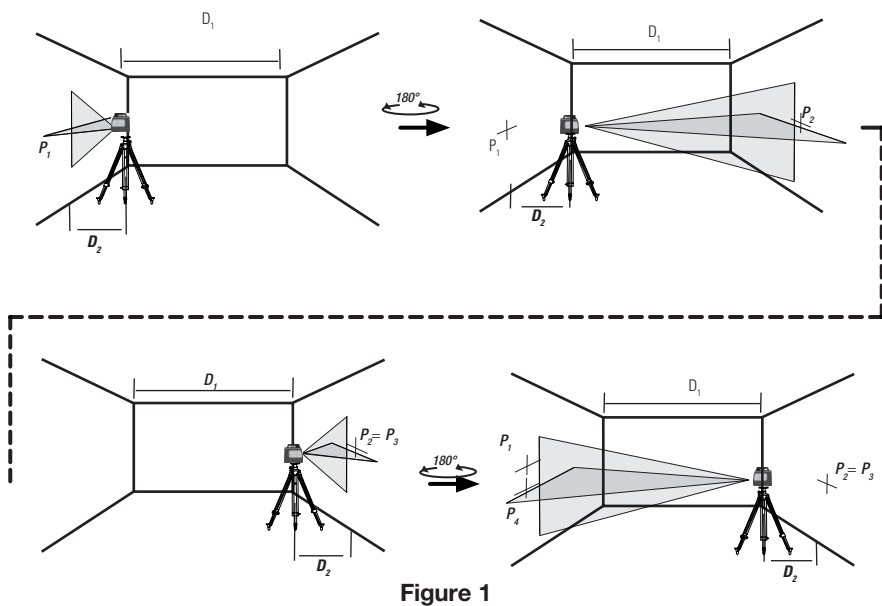

FIG. 4



FIG. 5

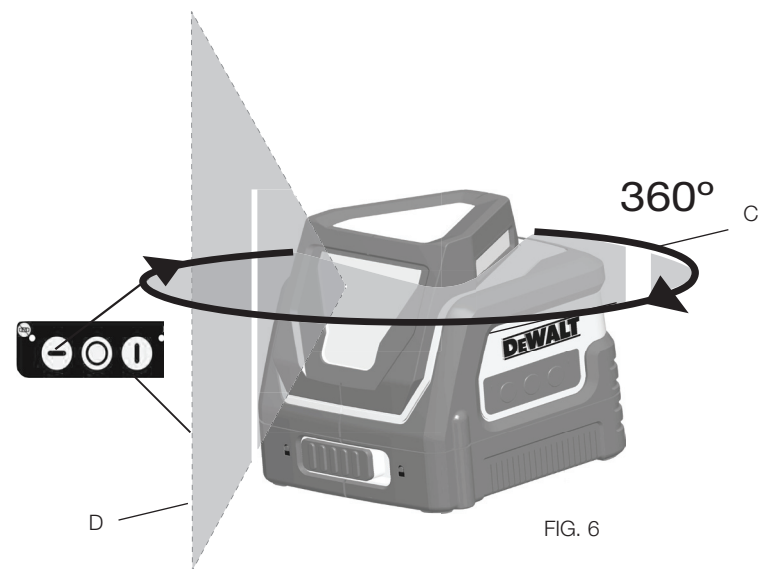

FIG. 6

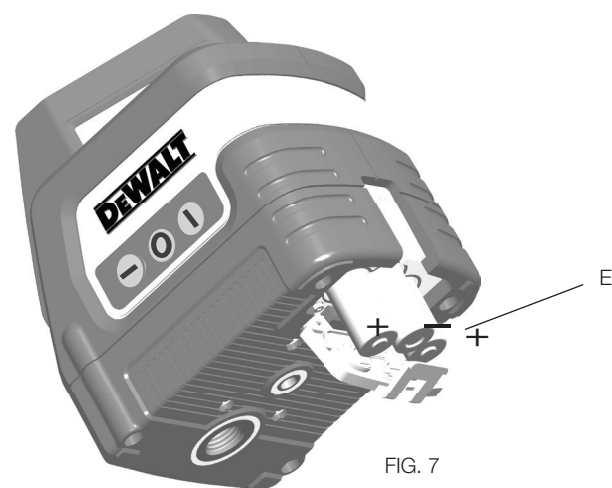

FIG. 7